

# PROCEEDINGS OF SPIE

[SPIDigitalLibrary.org/conference-proceedings-of-spie](https://spiedigitallibrary.org/conference-proceedings-of-spie)

## Conceptual design proposed for the M2-f/5-Nasmyth support system of the Telescopio San Pedro Mártir project

Gerardo Sierra Díaz, Joel Herrera Vázquez, Michael G. Richer, William H. Lee Alardin, J. Jesús González, et al.

Gerardo Sierra Díaz, Joel Herrera Vázquez, Michael G. Richer, William H. Lee Alardin, J. Jesús González, Rodrigo Dueñas Mendoza, "Conceptual design proposed for the M2-f/5-Nasmyth support system of the Telescopio San Pedro Mártir project," Proc. SPIE 10700, Ground-based and Airborne Telescopes VII, 107003M (6 July 2018); doi: 10.1117/12.2314943

**SPIE.**

Event: SPIE Astronomical Telescopes + Instrumentation, 2018, Austin, Texas, United States

# Conceptual design proposed for the M2-f/5-Nasmyth support system of the Telescopio San Pedro Mártir project

Gerardo Sierra Díaz<sup>\*a</sup>, Joel Herrera Vázquez<sup>a</sup>, Michael G. Richer<sup>a</sup>, William H. Lee Alardin<sup>b</sup>, J. Jesús González<sup>b</sup>, Rodrigo Dueñas Mendoza<sup>c</sup>,

<sup>a</sup>Instituto de Astronomía – Universidad Nacional Autónoma de México, Carretera Tijuana-Ensenada km107, Playitas, Ensenada Baja California México CP 22860. <sup>b</sup>Instituto de Astronomía – Universidad Nacional Autónoma de México Av. Universidad 3000, Circuito Exterior S/N Delegación Coyoacán, C.P. 04510. Ciudad Universitaria, Ciudad de México, México. <sup>c</sup>Centro de Enseñanza Técnica Y Superior, Camino Microondas Trinidad KM 1, Las Palmas 3era. Sección, Ensenada, Baja California, México. C.P. 22860

## ABSTRACT

The work that is presented is in its early stage. The intention of this document is to present the conceptual proposal of the design of the cell for Nasmyth-f/5 secondary mirror (TSPM-M2-f/5-Nasmyth), its support system and the mirror of this configuration for the “Telescopio San Pedro Mártir” (TSPM) project. In order to obtain more precise input data for the requirements of the telescope in terms of its: weight, center of gravity, interfaces with the telescope spider assembly and manufacturing viability. The goal of providing accurate data for the mechanical studies of the telescope was fulfilled. With this we ensure more realistic results in the opto-mechanics performance analysis of the whole telescope's. The telescope's requirements are the input data for the Opto - mechanics performance and survival analyses, both studies done by CIDESI. For this, it is necessary to have for this telescope configuration a conceptual proposal design of TSPM-M2-f/5-Nasmyth. We present the TSPM-f/5 Nasmyth support system proposal, which include the M2 cell, mirror and interface. Finite Elements Analyses (FEA) results of the support system and the mirror are presented too. In the conclusion we present some evidence of the pending future work for this study.

**Keywords:** TSPM, M2 support system, Opto-mechanics, Preliminary design.

## 1. INTRODUCTION

This project intends to construct a 6.5m telescope to be installed at the Observatorio Astronómico Nacional in the Sierra San Pedro Mártir in northern Baja California, Mexico. Initially TSPM is to operate in a f/5 Cassegrain configuration, before future definition and expansion to its other focal stations, including Nasmyth and folded Cassegrain configuration. Its Cassegrain configuration will be assembled around a closed design (converted MMT/Magellan telescope) with most of its optical parts already manufactured. To anticipate for future possible upgrades, the project has considered the design of an extreme f/5-Nasmyth configuration.

This configuration requires the development of a new secondary mirror (M2) and tertiary mirror (M3). The proposal for the conceptual design of TSPM-M2-f/5-Nasmyth is presented in this document. The mechanical and optical information of it define the requirements for the telescope structure. The Nasmyth-f/5 configuration of the 6.5m San Pedro Mártir Telescope drives the size of M3, as well as the telescope rigidity necessary to support its bulkiest M2 and M3. That is why; the configuration f/5-nasmyth is the most demanding for the telescope structure rigidity and foundations stiffness. The structure of the telescope must be ready to change to this configuration with in specification on astronomical performance and survival requirements. The telescope structure is being designed by a contractor. The project external contractor is the Center for Industrial Engineering and Development, “El Centro de Ingeniería y Desarrollo Industrial” (CIDESI). The goal of having a complete proposal for the conceptual design of TSPM-M2-f / 5-Nasmyth is to have more accurate input data in; weight, center of gravity, interfaces with the telescope spider assembly, manufacturing viability, to have a more realistic result in the mechanical performance analysis of the telescope. This information will also help for the future development of the position and orientation compensator M2 considered in the error budget. As well as its optics systems that will compensate position M2 during the observation and the misalignment in the optical axis of the telescope due to the tension of the gravitational structure and the thermal changes.

\*gerardo@asto.unam.mx; phone 011 52 646 174 4580 ext. 418; fax 011 52 646 174 4607; <http://www.astrosen.unam.mx>

Ground-based and Airborne Telescopes VII, edited by Heather K. Marshall,  
Jason Spyromilio, Proc. of SPIE Vol. 10700, 107003M · © 2018 SPIE  
CCC code: 0277-786X/18/\$18 · doi: 10.1117/12.2314943

It is estimated that the spider for M2 is mounted on a Vane-Ends and this information is also necessary for the calculation of the required mechanical resolution of this.

## 2. M2-F/5-NASMYTH MIRROR

### 2.1 M2-f/5-Nasmyth Overall geometry.

The overall dimensions of the TSPM-M2-f/5-Nasmyth proposal are: diameter of 2,100.00 mm and thickness of 208.93 mm. Figures 1 and 2 show drawings and detailed information.

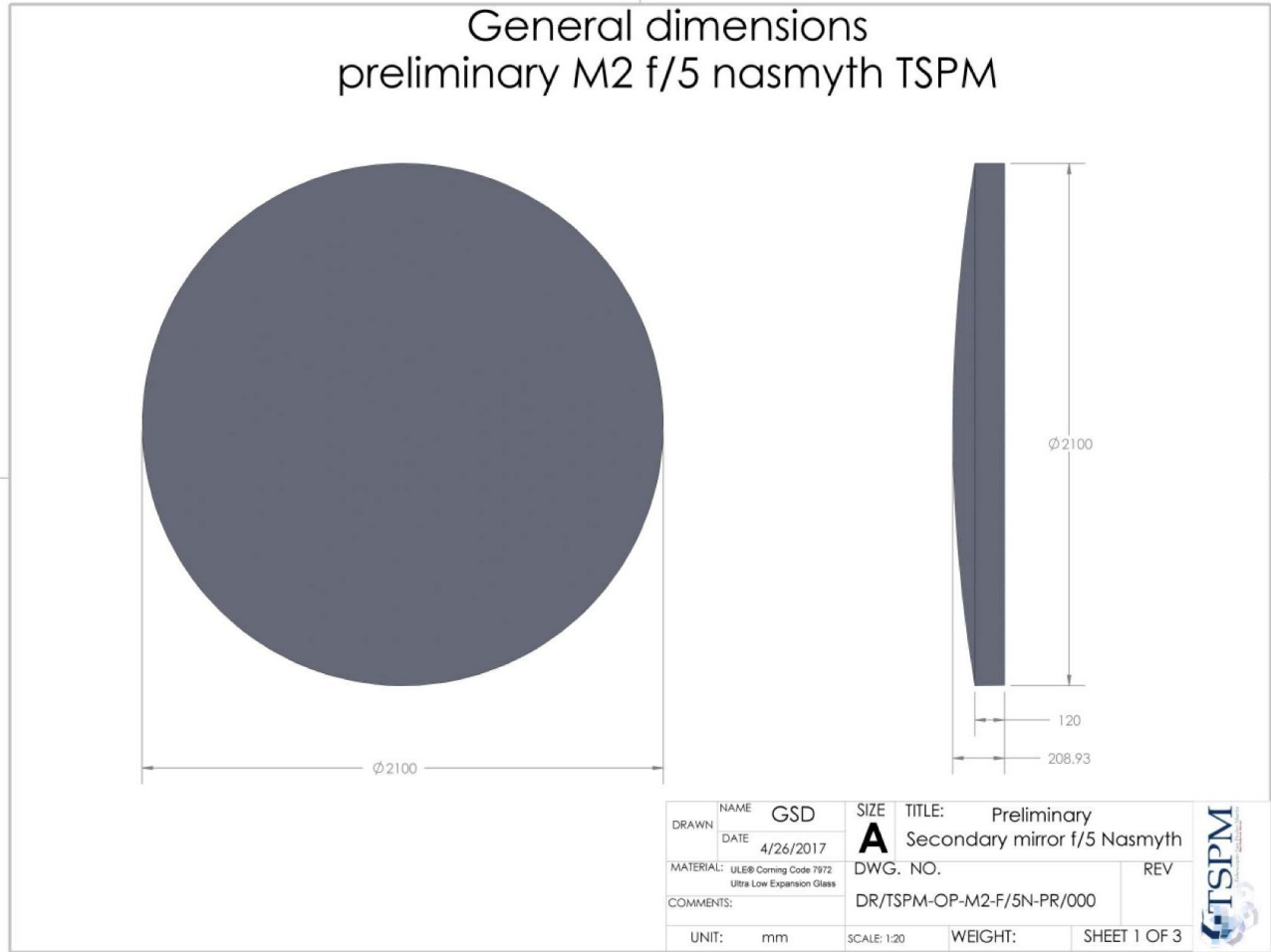

Figure 1. . Overall view with general dimension, TSPM-M2-f/. [Unit: mm].

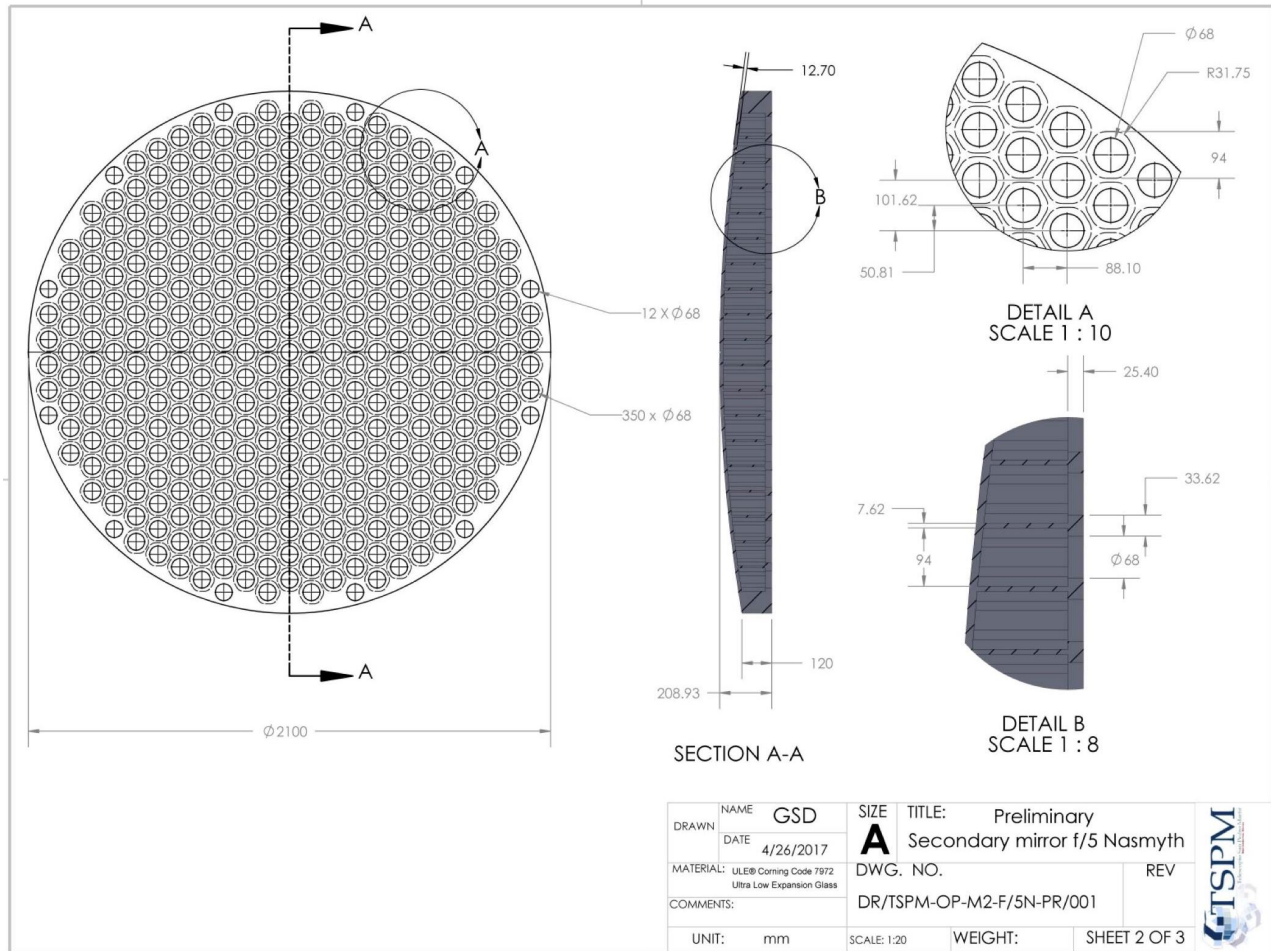

Figure 2. . Back, section and detail “A” and detail “B” views, TSPM-M2-f/5-Nasmyth. [Unit: mm].

## 2.2 TSPM-M2-f/5-Nasmyth, weight and center of gravity

The proposed conceptual design for the mirror has been lightened in its weight by means of holes. This lightening in weight of the mirror was performed in the same manner as for M2-f/5-Cassegrain. The same dimensions and spacings between the perforations have been used in M2-f/5-Nasmyth. This geometric data was obtained from the section "C-C" of the MMTC-001 drawing. REV. 3, SECONDARY MIRROR FABRICATION; from: the Observatories of the Carnegie Institution of Washington, Pasadena, California. The M2 f/5 Cassegrain mirror has 223 perforations, and in the proposed design for M2-f/5-Nasmyth it has 350 perforations. This increase is because the diameter of the M2-f/5-Nasmyth is 385.5 mm larger. The M2-f/5-Nasmyth has 12 new simple perforations that have been proposed at the periphery of the mirror. The perforations are detailed in figures 2.

The optical surface vertex for M2-f/5-Nasmyth is located at  $X=0$ ,  $Y=0$ , and  $Z= 5785.63$  mm, from the M1 optical surface vertex and the center of gravity of whole system supports for M2-f/5-Nasmyth (mounts and mirror) is located at  $X=0$ ,  $Y=0$ , and  $Z=6014.40$  mm from the M1 optical surface vertex as well. This is show in figure 3.

## 2.3 M2-f/5-Nasmyth Material proposal

The materials that were analyzed for the TSPM-M2-f/5-Nasmyth are: ULE® Corning © Code 7972 (Ultra Low Expansion Glass) and Zerodur® by Schott ©. The first is a titania silicate glass with unique characteristics that has made it the material of choice in applications ranging from machine tool reference blocks to solid and lightweight mirror blanks for astronomical telescopes. The second material is an inorganic, non-porous lithium aluminum silicon oxide glass ceramic characterized by evenly distributed nano-crystals within a residual glass phase. The M2-f/5-Cassegrain

material is Zerodur® by Schott©. At the time of this document and after several FEA runs, Zerodur by Schott © is selected for the M2-f/5-Nasmyth material.

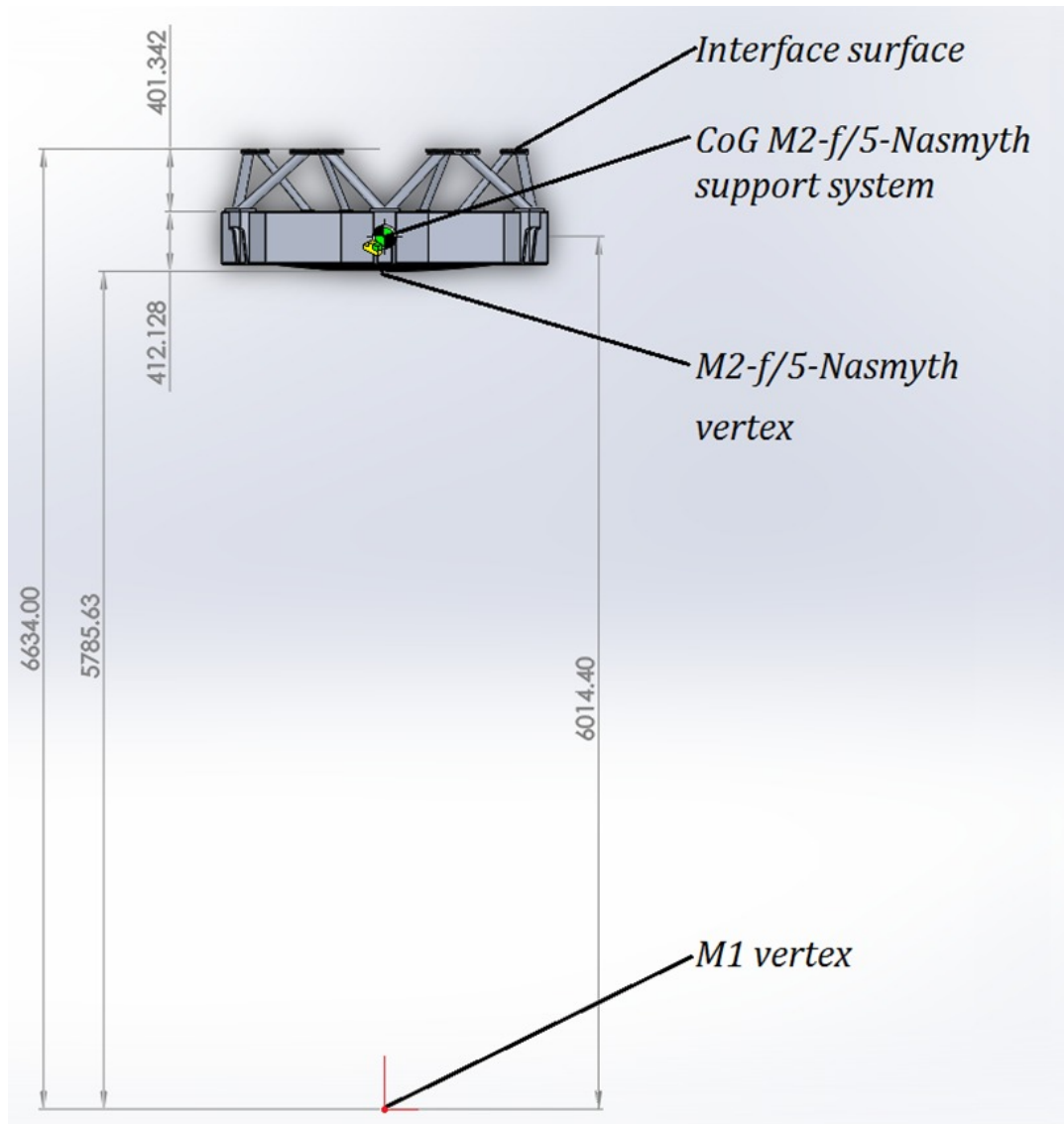

Figure 3. Schematic of the center of gravity location of the M2-f/5-Nasmyth support system. Reference with M1 optical surface vertex. [Unit: mm].

## 2.4 Geometric similarities and differences among the TSPM-M2-f/5, Cassegrain and Nasmyth

The similarities between the mirrors are the general dimensions of the central perforations that lightened their weight. In both mirrors the perforations have the same measurements. The M2 material is the same for both configurations.

One of the main differences between the mirrors is; the irregular perforations near the perimeter that lightened the M2 Cassegrain's weight are not present in M2 Nasmyth. Other differences among them include the overall dimensions of the mirrors. In diameter, M2 Nasmyth is 385.5mm larger than M2 Cassegrain, and in thickness, M2 Cassegrain is 1.07 mm thinner than M2 Nasmyth. Therefore, there is a variance of 247.37kg between both M2 mirrors in weight: M2 Cassegrain's is 318 Kg and M2 Nasmyth's is 565.37 kg. Another difference is the curvature of the optical surfaces.

### 3. BRIEF HISTORY OF THE WORK DONE PREVIOUSLY.

We present a brief history of the work done previously. This work is in its initial stages. We started with a system of three Whippletrees of 6 points each one, for a total of 18 points of contact, but the results obtained of FEA were out of specifications, particularly in the center of the mirror presented large deformations by gravity. The gain of this study was the knowledge of the best physical distribution of the 18 points of contact, respecting the holes on the back of the mirror, balancing the weight of the mirror and minimizing deformations of the optical surface, despite not reaching the optical specifications.

Given the above results, a fourth 6-point Whippletree system was added in the center of the cell increasing to 24 points of contact. This system efficiently distributes the weight of the telescope and keeps the mirror in the axial axis, but not in the plane perpendicular to it, so it is necessary to add lateral supports. Likewise, in this second group of iterations the results obtained by FEA were not satisfactory either.

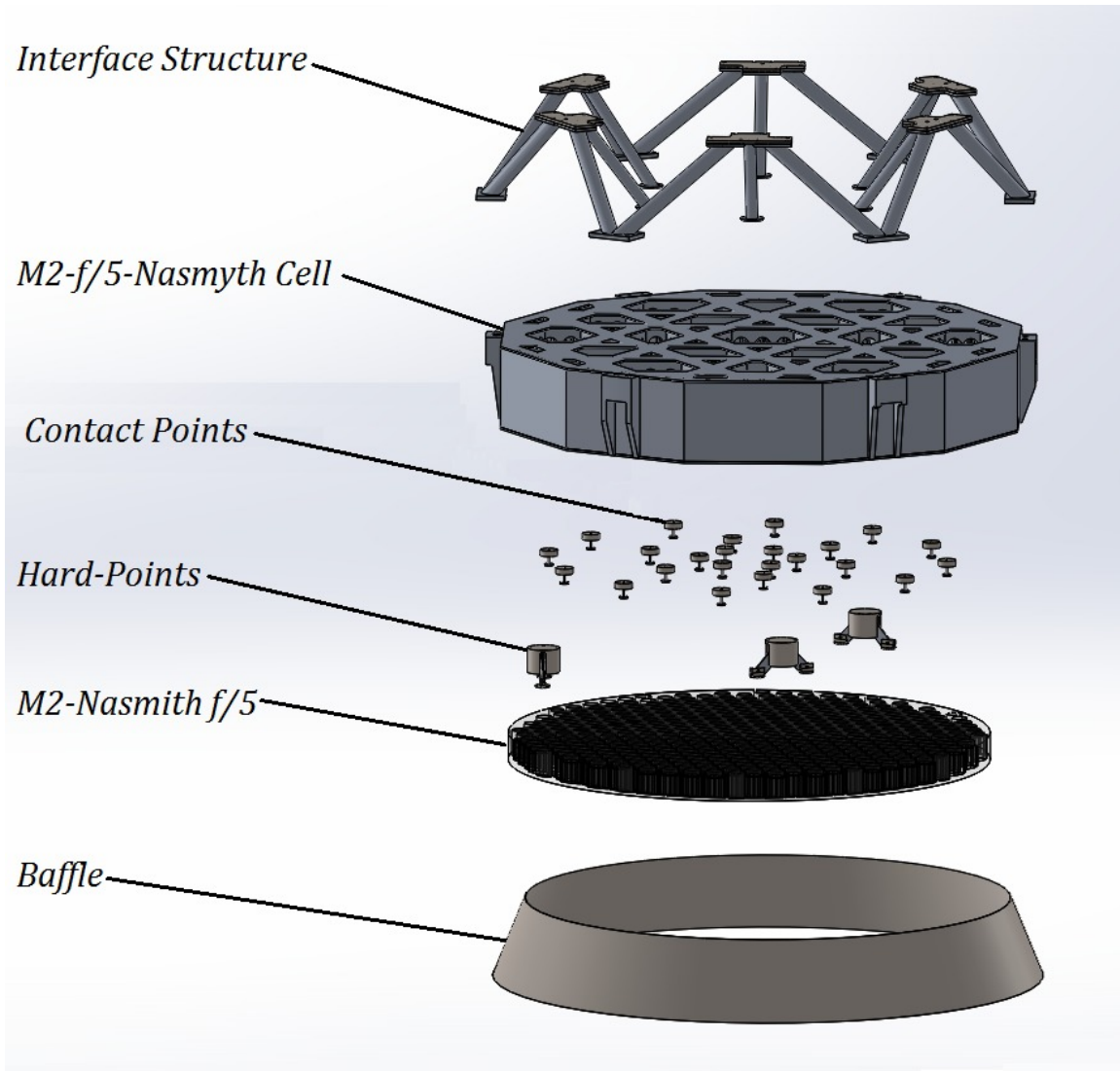

Figure 4. Components of the TSPM-M2-f/5-Nasmyth support system.

## 4. M2-F/5-NASMYTH MIRROR SUPPORT SYSTEM PROPOSAL

The main goal of mirror support system is to hold the mirror in the telescope so that the forces of gravity, wind, telescope acceleration and vibration do not significantly distort the optical surface of the mirror. The only disturbance “or loads” analyzed that contributes to the FEA so far is gravity.

Although the proposed cell for M2-Nasmyth-f/5 is similar in form with f/5-Cassegrain cell, their weights are different because the M2-f/5-Cassegrain cell is active while the M2-f/5-Nasmyth-cell proposal is static, rigid and passive compensated. The M2-f/5-Cassegrain cell weights 160 Kg and the M2-f/5-Nasmyth cell 558.16 Kg. In figure 4, the components of the TSPM-M2-f/5-Nasmyth support system proposal are shown. Each section will be described below, with exception of the baffle. Pending: thermal, wind, and dynamic FEA. It is understood that a rigid and passive support system needs a heavier and more robust cell. As explained in the introduction to this document, the extreme f/5-Nasmyth configuration of TSPM drives the telescope rigidity necessary to support its most massive M2. It is for this reason that a static, rigid and passive compensated mirror support with hard-points is presented, leaving pending the design of an active and lighter cell

### 4.1 Interface on the back surface of the mirror

Given the past results, presented in this document in section 3, it was decided to remove the whiplight systems, so the contact points were attached directly to the cell and to the back of the mirror with pads joining them with round bars of 6.35mm in diameter. The locations of these fixed points are the same as the 24 contact points used in previous analyzes. Figure 5. Three lateral supports were introduced which are oriented in such a way that the forces resulting from the lateral supports hold the mirror in the plane perpendicular to the axial axis. These new fixed points are those that give lateral support to the mirror. To these new rigid points we call them hard-points and are a triangular mount that has a point of attachment to the cell and 2 to the mirror. We understand that the assembly of the mirror with this type of rigid frame is difficult because the rear plane of the mirror is over defined with 30 fixed points, which must be at the same height. Show details and results of this analysis is the purpose of this document

The 3 hard-point distribution on the back of the mirror is presented in figures 5 and 6. Each hard-point has 2 contact points to the back surface mirror.

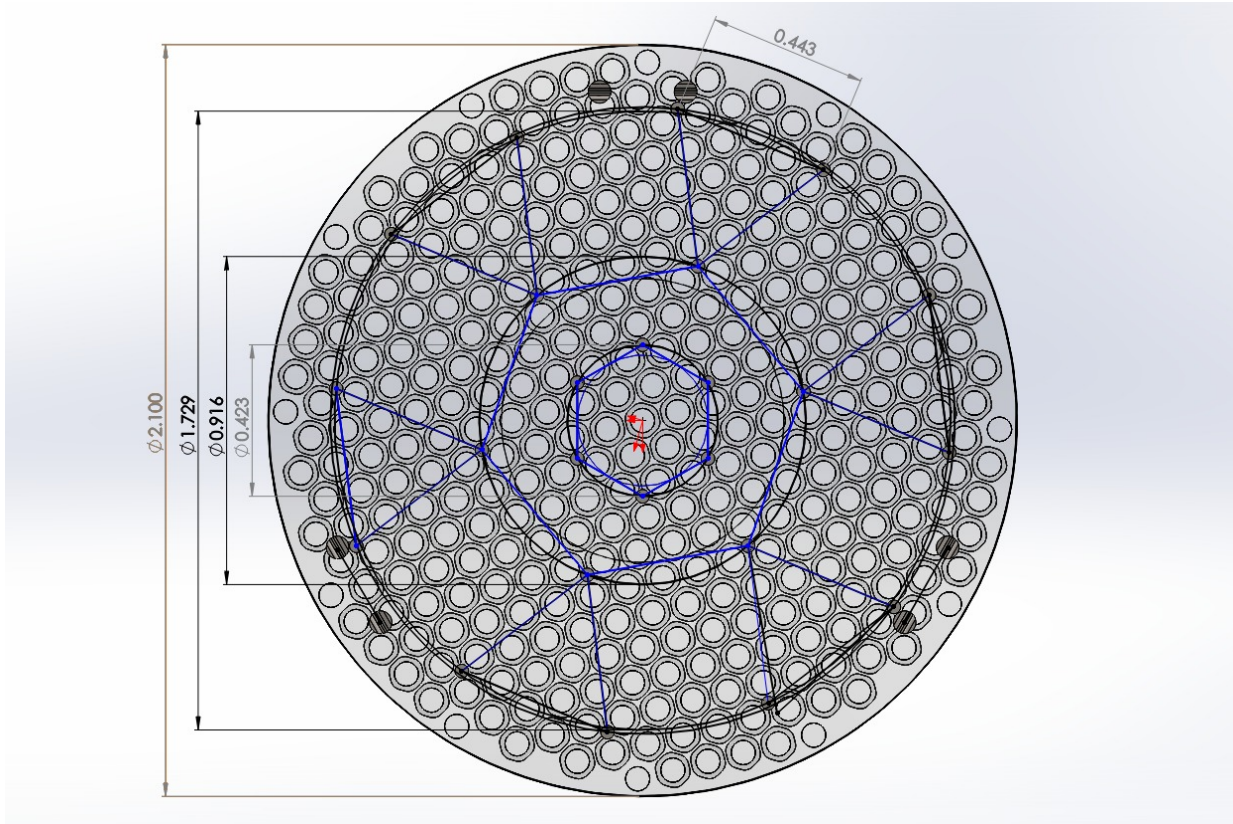

Figure 5. Show the distribution of the 24 contact points and the 6 contact points of the hard-points. [Unit m]

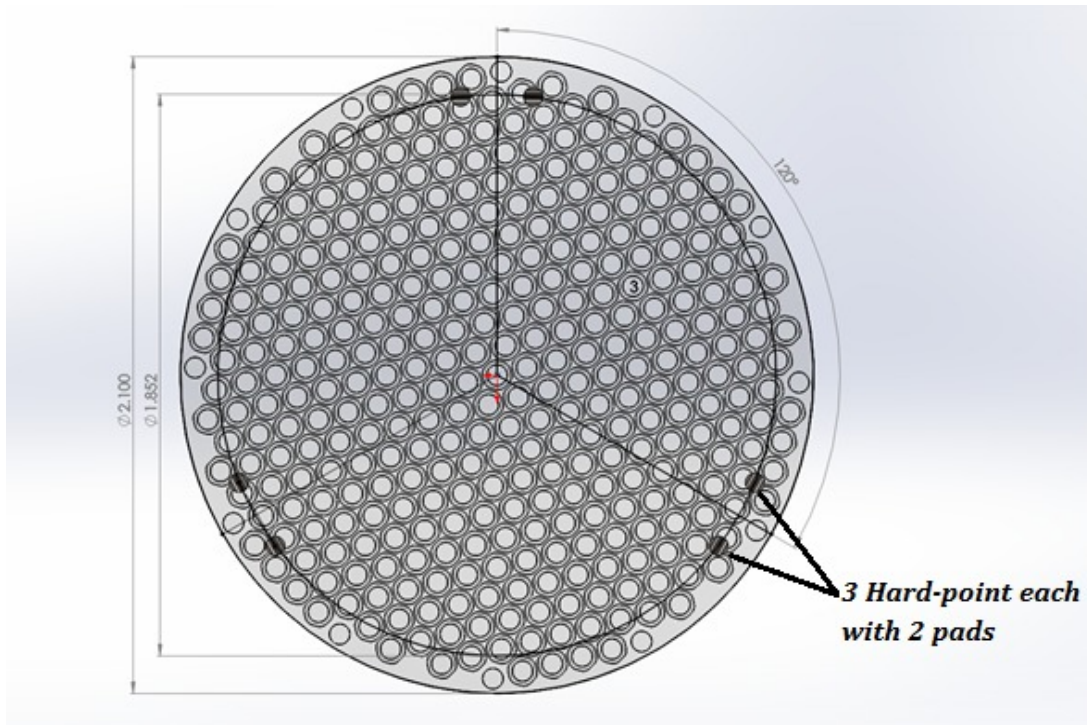

Figure 6. Show the distribution 6 contact points between the hard-points and the back surface of mirror. [Unit m]



## 4.2 Interface structure

The Nasmyth and Cassegrain telescope configurations don't share the same secondary mirror position at the telescope for its f/5 configuration. The interface structure will allow the M2 Nasmyth to be mounted on the same M2-Cassegrain telescope spider interface. The interface structure is designed in order to adjust perfectly to the interface mounting holes and surface of the TSPM-M2-spider. It compensates the difference in position too. It is an all-aluminum tubular structure that holds the M2-Nasmyth-f/5-cell to the telescope spider. The tube's diameter is 50.80 mm with 8.00mm thickness and the rest of the interface structure is aluminum plate.

Figure 7 shows the general dimensions of the interface structure and details the mounting surface and holes.

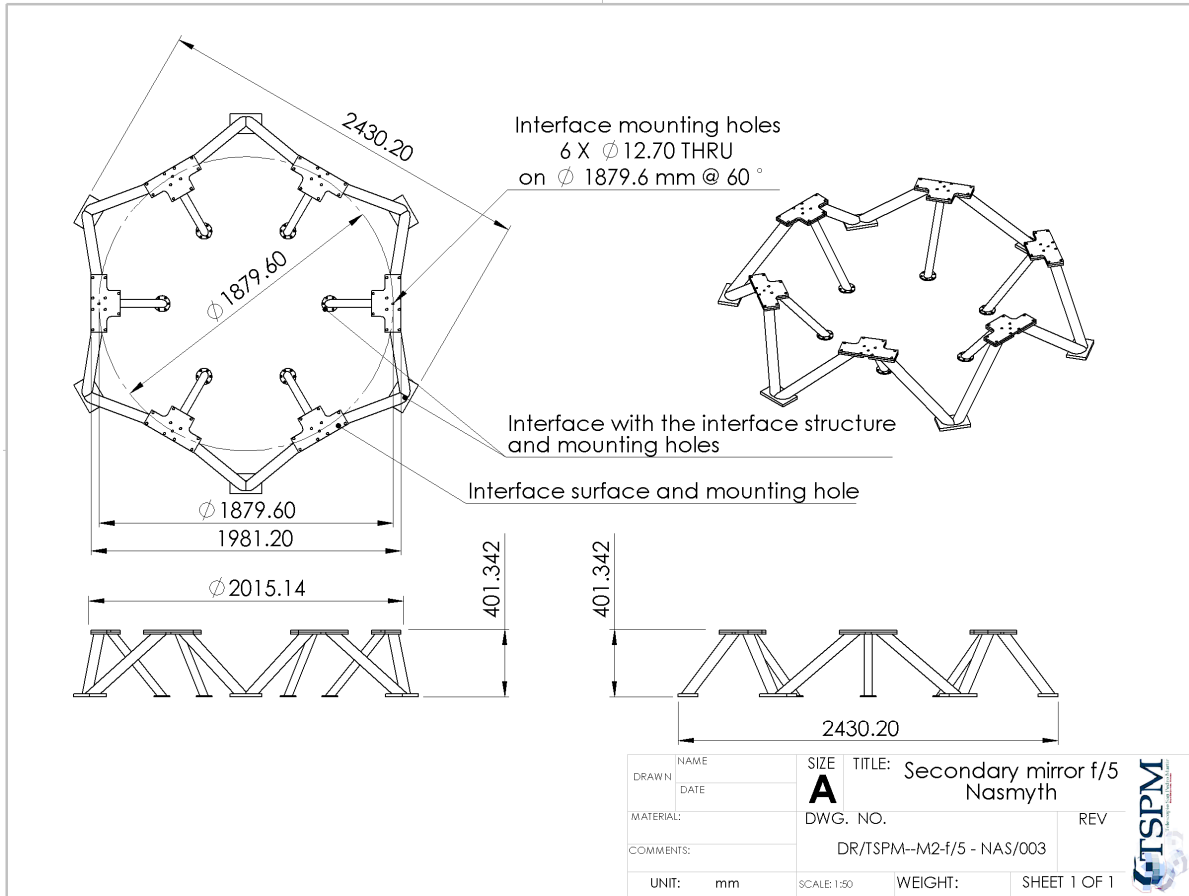

Figure 7. General dimension of the interface structure and detail of the mounting surface and holes. [Unit: mm].

## 4.3 The M2-f/5-Nasmyth cell.

The secondary mirror cell has the shape of a dodecagon prism with a height of 365.13mm and an edge to edge length of 2,252.4mm. The secondary mirror cell holds the contact points and the hard points, and it is screwed to the interface structure at its top, by six external brackets and the top plate. It is made of aluminum plates. M2-f/5-Nasmyth cell's general dimensions and details are shown in figure 8.

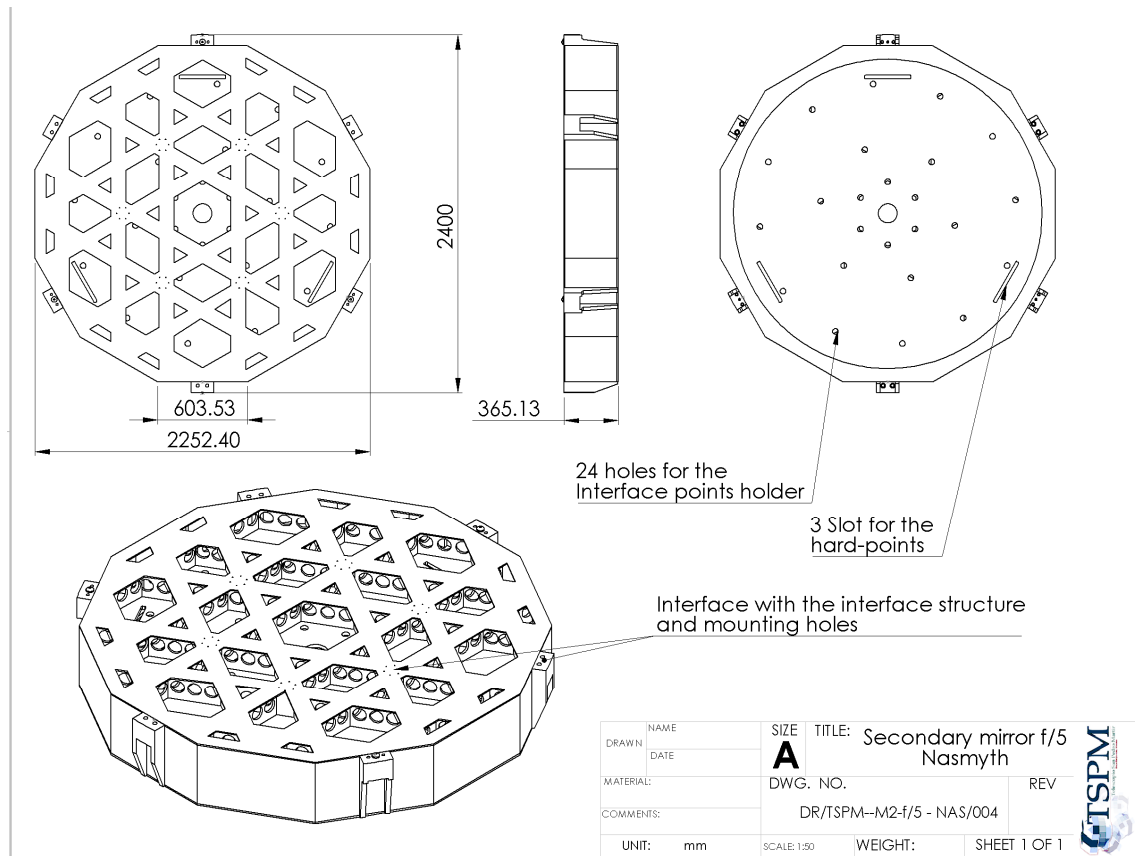

Figure 8. M2-f/5-Nasmyth cell general dimension and details. [Unit: mm].

#### 4.4 The Hard-point system and the contact point system.

The contact points and hard-points systems that support the axial movement of the mirror have not been design in detail for the TSPM-M2-f/5-Nasmyth support system yet. It must have an active compensator system with actuator embedded in order to improve the image quality. It is presented in this document as it was modeled for the Finite Elements Analysis. Figure 9 shows the model of the hard-point with general dimensions and the models of the contact points system.

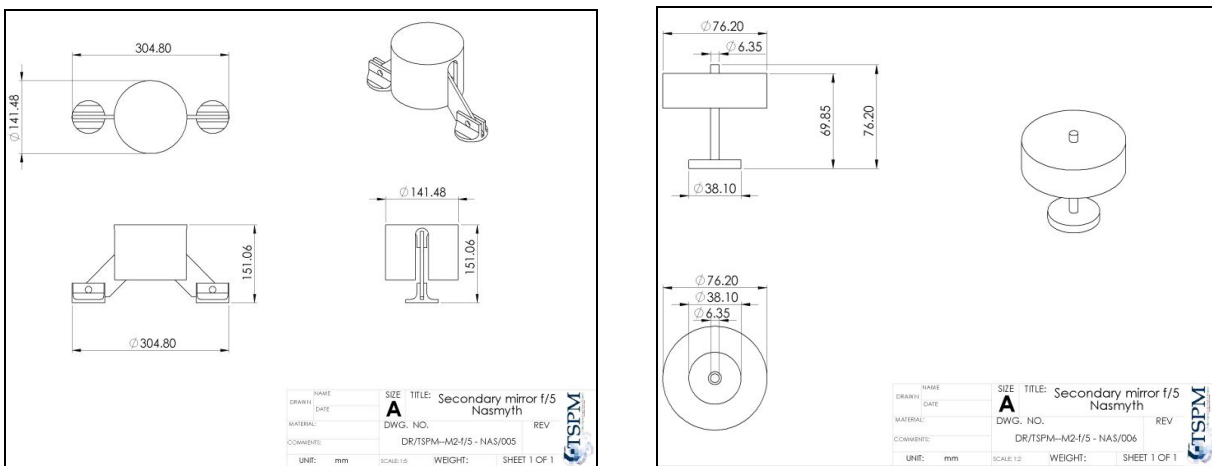

Figure 9. Left: Model of the M2-f/5-Nasmyth cell hard-point with general dimensions. Right: Models of the contact points for M2-f/5-Nasmyth-cell. [Unit: mm].

## 5. THE FEA ANALYSIS FOR THE M2-F/5-NASMYTH MIRROR SUPPORT SYSTEM PROPOSAL

Finite element analysis (FEA) was used to predict the mechanical behavior of the M2-f/5-Nasmyth Mirror support system. Three types of FEA analyses were used: (1) Static Stress with Linear Material, (2) Natural Frequency (Modal), and (3) Natural Frequency (Modal) with Load Stiffening

The first type on analysis is done to check the structure's response to the gravity acceleration loads, and are presented in document's section 5.3, where the results of the whole support system (mounts and mirror) are show, and in document's section 5.4, the mirror's results are isolate, of the same analysis, this results' isolation is done because the mirror optical surface is from where the optical error budget analysis takes its data. The second and third types of analyses are done to obtain natural frequency of the whole support system, and the results are show in section 5.5 of this document.

### 5.1 FEA Model details

The simulations were performed in the Autodesk Simulation Mechanical 2015 © software. The last analyses performed until now are presented. The types of analysis performed in FEA were; static stress with linear material, Natural Frequency (Modal) and Natural Frequency (Modal) with Load Stiffening analysis. Gravity was the only load included as a disturbance element. All these analyses are static and all material strains are in the linear elastic range. The simulated conditions of the mirror were when the telescope is pointing to; zenith, at 45 degrees from zenith and to horizon. It was simulated by changing the g-vector. G-vector orientations are:  $-Z$  when telescope in pointing to zenith, on the plane  $Y-Z$ ,  $-45^\circ$  from  $-Y$  axis when the telescope is pointing @45 from zenith and  $-Y$  when the telescope is pointing to horizon. Figure 11, bottom. The same model was used for all the analyses. Presented below are details of the model used and the considerations taken.

### 5.2 Model general information and considerations

The number of the FEA model nodes: 155,631. The element type: Brick. The number of parts: 156. The coordinate system for all FEA models presented in this document, the z-axis points is contrary to the z-axis defined in the M2 coordinate system. The MKS units system was used. And the same color scale is applied in all FEA results, red for the highest and blue for the lowest.

The material used for the mirror is Zerodur® by Schott ©. The material for the contact points and hard-points systems is Stainless Steel AISI-202. The baffle material is DuPont© Delrinr 550SA, GP Acetal Homopolymer. The rest of the TSPM-M2-f/5-Nasmyth support system material is Aluminum alloy 2014-T6. The constrained nodes are completely fixed and are localized on the surface interface with the telescope M2 spider. Figure 10 shows a graphic representation of the model's boundary conditions. The red triangles on the top of the image represent the completely fixed nodes of the boundary conditions.

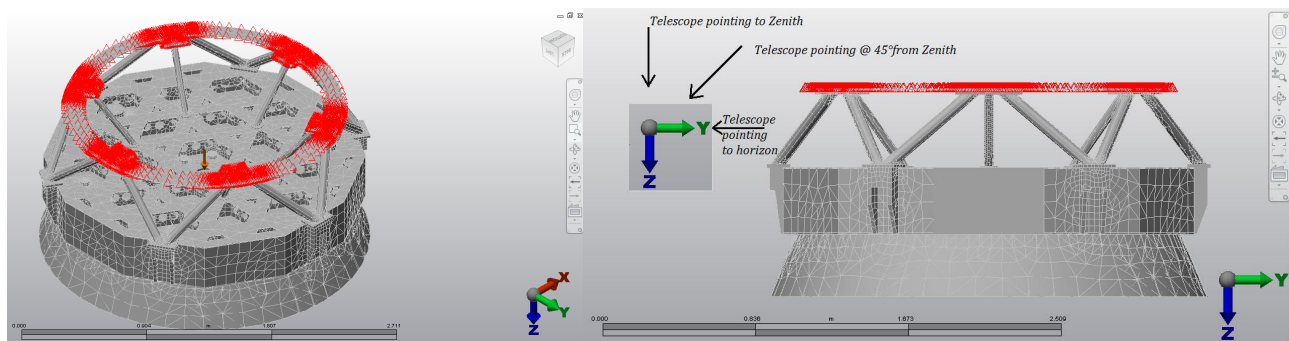

Figure 10. Left: Graphic representation of M2-f/5-Nasmyth support system FEA model, showing the location of the boundary conditions, and the g-vector direction in the center. Right: g-vector orientation for the FEA analyses.

### 5.3 FEA Model results (Static)

The results obtained from the Static Stress with Linear Material FEA of the M2-f/5-Nasmyth support system are presented. Table 1 shows the result summary and figures from 11 to 13 shows in graphics the M2-f/5-Nasmyth support system FEA results.

The maximum stress is presented in the same place in the three analyzes presented and is located in the thinnest part of the interface points between the cell and the back of the mirror. This is on the middle of the 6.35 mm diameter bar. The minimum effort is also presented in the three analyzes in the same place and is located in the upper ring part, in the middle, between the mounting holes.

The maximum and minimum deformations also occur in the same piece of the M2 support. The minimum deformations are located in the upper ring and the maximum deformations in the lower part of the baffle.

Table 1. Summary of FEA static analysis M2-f/5-Nasmyth support system.

Static Stress FEA Result of the M2-f/5-Nasmyth support system			
Telescope pointing direction	Stress [Location]		Deformation
	Max. [Pa] [All on the middle of the connection points]	Min. [Pa] [All on the top interface in between the holding holes]	
Zenith	$8.5429 \times 10^6$	15.3759	11.97820
@ 45 ° from Zenith	$16.707 \times 10^6$	52.35	30.07522
Horizon	$17.381 \times 10^6$	52.1324	38.50930

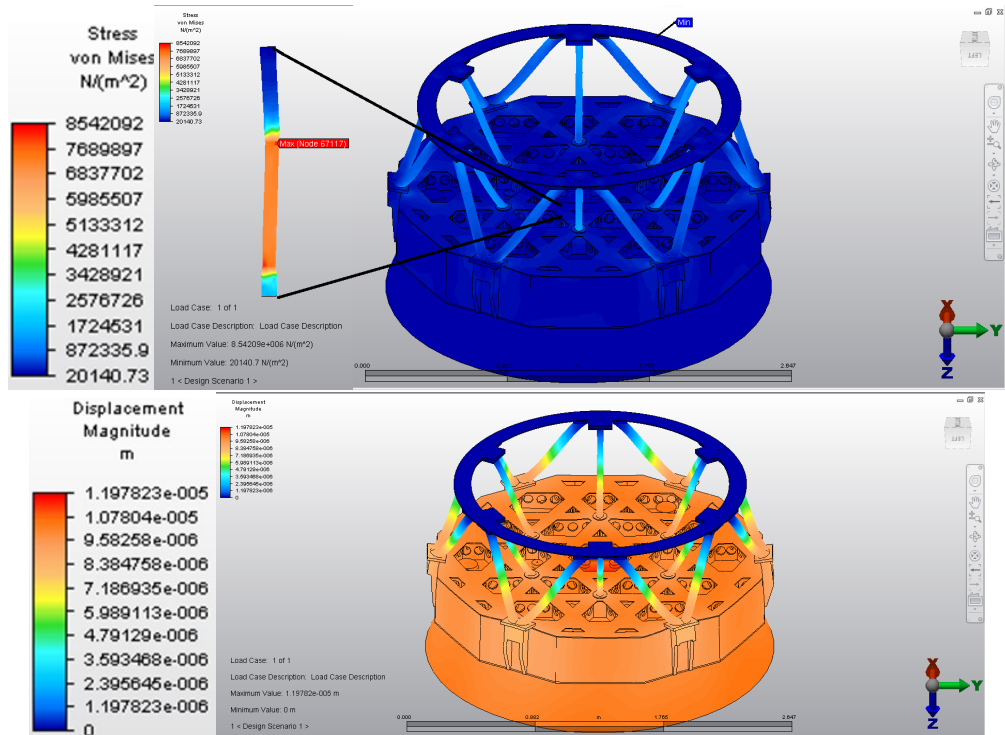

Figure 11. Graphic representation of the M2-f/5-Nasmyth support system FEA result, with the telescope pointing to Zenith. Top; Stresses results and detail of the 6.35 mm diameter bar. Bottom; Deformations results.

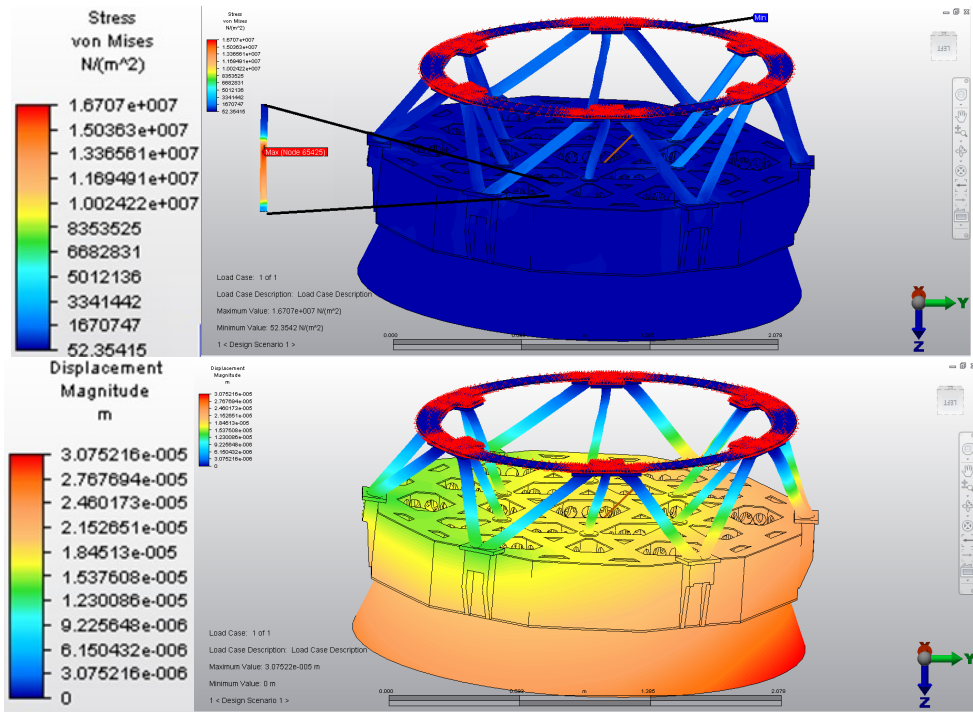

Figure 12. Graphic representation of the M2-f/5-Nasmyth support system FEA results, with the telescope pointing to 45° from Zenith. Top; stresses results and detail of the 6.35 mm diameter bar. Bottom; deformations results. The red triangles on the top of the images represent the completely fixed nodes of the boundary conditions and the g-vector direction as an orange line at the center.

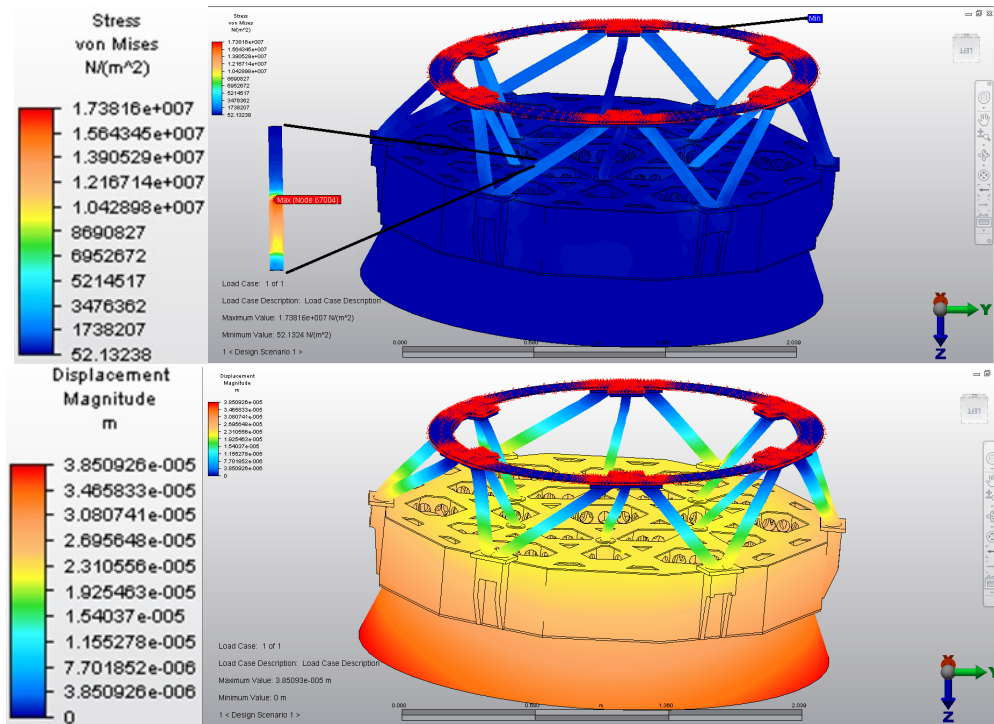

Figure 13. Graphic representation of the M2-f/5-Nasmyth support system FEA results, with the telescope pointing to horizon. Top; stresses results and detail of the 6.35 mm diameter bar. Bottom, the red triangles on the top of the image represent the completely fixed nodes of the boundary conditions.

### 5.4 The mirror FEA Model results (Static)

This section is presented because the optical element results are the most relevant for the evaluation of the M2-f/5-Nasmyth support system. The FEA results of the mirror supported on the system are presented in this section. Below are the maximum and minimum stress and deformation values present in the mirrors and the maximum and minimum deformation values present on the mirror optical surface. The contribution to the telescope error budget must be smaller than 0.051 arc second. It is discussed later, in this same document in the "Conclusions" and "Pending Future Work" sections, on the non-compliance with the optical specification on the maximum contribution for the telescope error budget. Table 2 show a result summary of the static stress with linear material FEA of the mirror placed on the f/5-Nasmyth support system is, as well as in a graphic form it is presented in figures 14 through 16

Table 2. Summary of FEA static analysis M2-f/5-Nasmyth support system.

Static Stress FEA Result of the M2-f/5-Nasmyth							
Telescope pointing direction	Stress		Deformation [ $\mu\text{m}$ ]				Contribution to the telescope error budget FWHM arc sec.
			All the mirror [ $\mu\text{m}$ ]		On optical surface [ $\mu\text{m}$ ]		
	Max.[Pa]	Min.[Pa]	Max.	Min.	Max.	Min.	
Zenith	750,680	3143.62	11.97	9.81	11.97	9.81	0.105
@ 45° from Zenith	1.27007 X 10 <sup>6</sup>	3129	25.28	18.31	25.28	19.59	0.107
Horizon	1.13559 X 10 <sup>6</sup>	2553.88	30.46	25.71	30.46	26.9	0.101

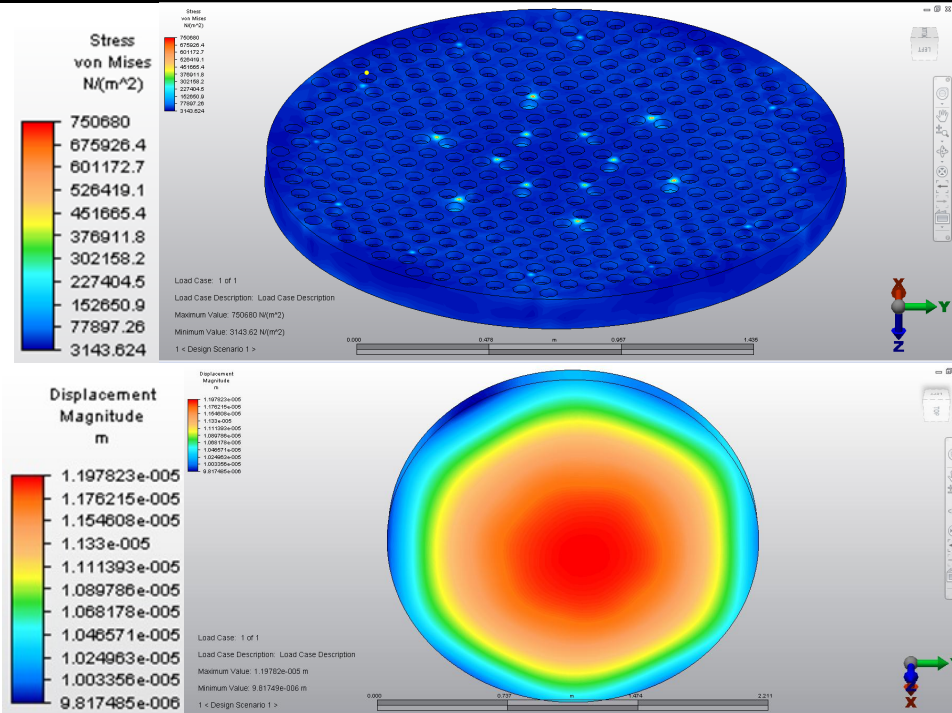

Figure 14. Graphic representation of the mirror- f/5-Nasmyth FEA result, with the telescope pointing to Zenith. Top; Stresses results. Bottom; Deformations results.

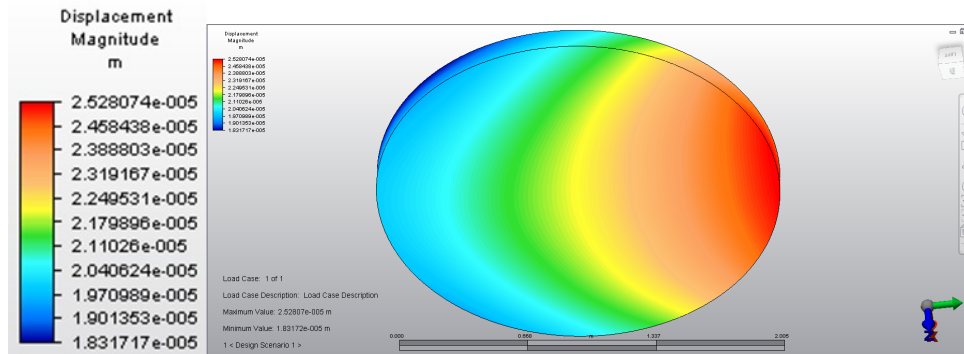
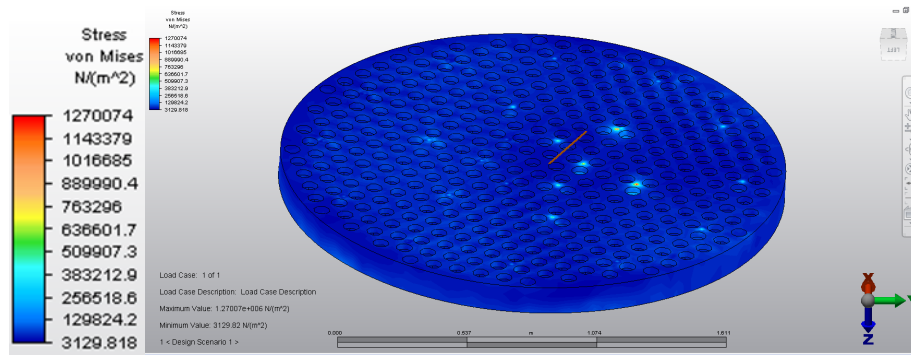

Figure 15. Graphic representation of the M2-f/5-Nasmyth support system FEA results, with the telescope pointing to Zenith. Top; stresses results and detail of the 6.35 mm diameter bar. Bottom; deformations results.

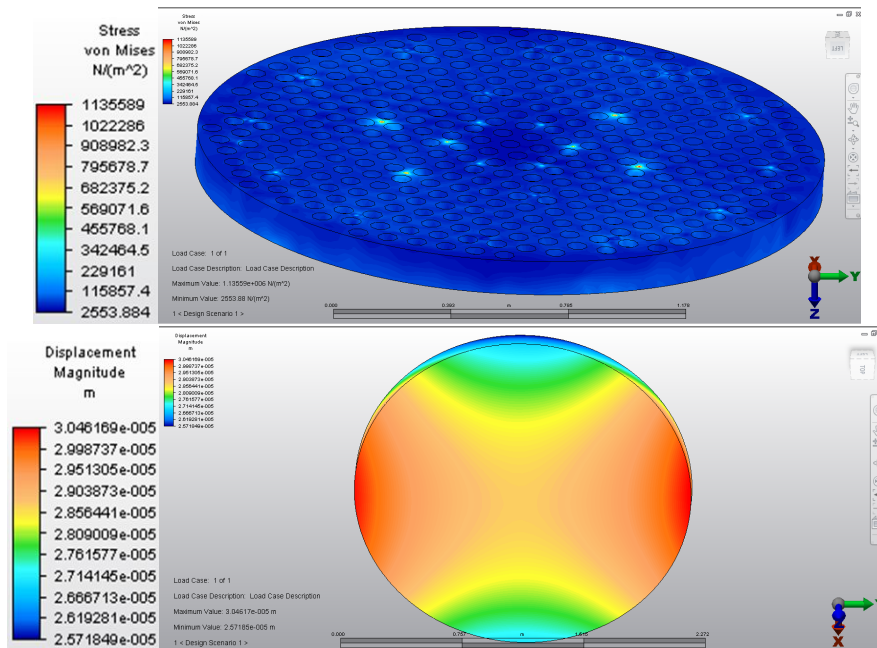

Figure 16. Graphic representation of the mirror-f/5-Nasmyth FEA results, with the telescope pointing to horizon. Top; stresses results. Bottom; deformations results.

### 5.5 The modal FEA Model results

The results obtained from the Natural Frequency (Modal) and Natural Frequency (Modal) with Load Stiffening finite elements analyses of the M2-f/5-Nasmyth support system are presented below. Table 3 shows the summary of these results and figure 17 it presents them in graphics form.

Table 3: Summary of FEA modal analysis M2-f/5-Nasmyth support system

Natural frequency	Natural frequency Value in Hz	Vibration Mode
1	93.76	Bell-type on the Y-axis
2	94.73	Bell-type on the X-axis
3	154.05	Spring-type up and down
4	161.12	Torsional spring type around the Z axis
5	191.79	Bell-Type around the center of gravity

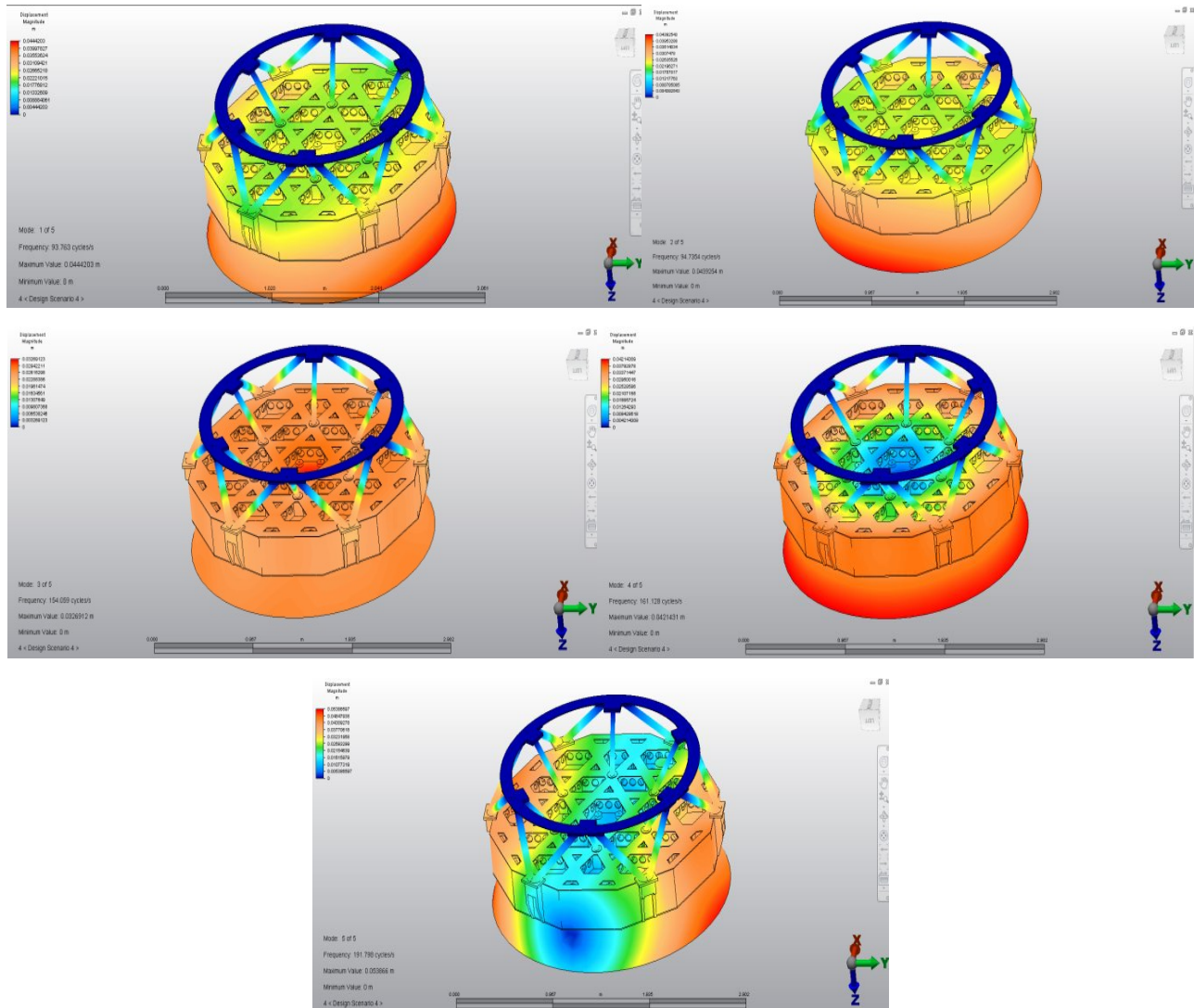

Figure 17. Graphics of the Natural Frequency (Modal) of the first 5 natural frequencies. It shows its displacement.



## 6. CONCLUSION

The work presented is in its early stages. The input information that is needed for the telescope opto-mechanics performance analysis, done by CIDESI, from the TSPM-M2-f/5-Nasmyth support system proposal, has been delivered. The approximate weight is 1,320 kg. The location of center of gravity of the system, reference to the M1 optical surface vertex is  $X = 2.3769$  mm,  $Y = 0.47886$  mm,  $Z = 6014.40$  mm. The interface surface and mounting holes that TSPM-M2-spider used to hold the M2-f/5-Cassegrain cell, will be the same for mounting M2-f/5-Nasmyth support system.

The stresses FEA result presented that all material strains are in the linear elastic range. The maximum stress on the metal is 17.3 MPa present in the contact points and for the mirror glass is 1.2 MPa present in the top surface. The mirror back surface interface distribution has been studied and it may be possible to increase the number of the contact points. The M2-f/5-Nasmyth mirror can be thinner in order to lighten its weight and have a better response to the active system.

The present study shows evidence that the proposed TSPM-M2-f/5-Nasmyth support system needs active optical systems, which have not been developed, yet. The FEA deflections results of the mirror optical surface generated an optical contribution to the image quality in terms of FWHM as follows; 0.105 arc seconds when the telescope is pointing to Zenith, 0.107 arc seconds when pointing at 45 degrees and 0.101 arc second when the telescope is pointing to horizon (R.2). As these values are not acceptable at the image quality budget, next step is adding to the support system a controlled active compensated system axial and lateral, with controlled whiplight system as well as controlled hard-points.

## 7. PENDING FUTURE WORK

It remains to analyze the behavior of the optical surface to the disturbances of the wind, thermal, modal and the own movements of the telescope. The design of an active compensator is still pending that will contain the controlled whiplight and hard-points in order to achieve the image quality requirement. The second choice is to do reverse engineering of the M2-f/5-Cassegrain cell.

Current performance causes a maximum contribution of 0.107 arc second in the FWHM. In order for the telescope error budget meet the requirement of a total FWHM of 0.56 arc second the contribution of M2-f/5-Nasmyth should be at most 0.051, which will be achieved by incorporating an active system in the future.

## REFERENCES

- [1] Robert G. Fata, Daniel G. Fabricant, "Design and support of the 1.7-m f/5 secondary mirror for the MMT conversion," Proc. SPIE 2199, Advanced Technology Optical Telescopes V, (1 June 1994)
- [2] Shawn P. Callahan, Brian Cuerden, Daniel G. Fabricant, B. Martin, "The MMT f/5 secondary support system: design, implementation, and performance," Proc. SPIE 5495, Astronomical Structures and Mechanisms Technology, (29 September 2004)