

# PROCEEDINGS OF SPIE

[SPIDigitalLibrary.org/conference-proceedings-of-spie](https://spiedigitallibrary.org/conference-proceedings-of-spie)

## Telescopio San Pedro Mártir Observatory final design

Jose Teran, William H. Lee, Michael G. Richer, Beatriz S. Sanchez, David Urdaibay, et al.

Jose Teran, William H. Lee, Michael G. Richer, Beatriz S. Sanchez, David Urdaibay, Regina Hernandez-Limonchi, Jacob Lauderdale, Allan Ortega Gutiérrez, Cory Lindh, "Telescopio San Pedro Mártir Observatory final design," Proc. SPIE 10700, Ground-based and Airborne Telescopes VII, 107002N (6 July 2018); doi: 10.1117/12.2309953

**SPIE.**

Event: SPIE Astronomical Telescopes + Instrumentation, 2018, Austin, Texas, United States

# Telescopio San Pedro Mártir Observatory Final Design

Jose Teran<sup>a</sup>, William H. Lee<sup>b</sup>, Michael G. Richer<sup>c</sup>, Beatriz S. Sanchez<sup>b</sup>, David Urdaibay<sup>b</sup>,  
Regina Hernandez-Limonchi<sup>a</sup>, Jacob Lauderdale<sup>a</sup>, Allan Ortega Gutiérrez<sup>a</sup>, Cory Lindh<sup>d</sup>

<sup>a</sup> M3 Engineering & Technology Corp. 2051 W. Sunset Rd. Tucson, AZ 85704 USA

<sup>b</sup> Instituto de Astronomía, UNAM, Ciudad Universitaria, Mexico City, Mexico

<sup>c</sup> Instituto de Astronomía, Universidad Nacional Autónoma de México, km 107 Carretera Ensenada-Tijuana, Ensenada, BC, Mexico

<sup>d</sup> Uni-Systems Engineering 4600 Lake Road Minneapolis, MN 55422 USA

## ABSTRACT

The Instituto de Astronomía of the Universidad Nacional Autónoma de México (UNAM) along with Instituto Nacional de Astrofísica, Óptica y Electrónica, the University of Arizona and the Smithsonian Astrophysical Observatory are developing the *Telescopio San Pedro Mártir* (TSPM) project, a 6.5m diameter optical telescope. M3 Engineering & Technology Corp. (M3) is the design and construction administration firm responsible for all site infrastructure, enclosure and support facilities.

The *Telescopio San Pedro Mártir* project (TSPM) will be located within the San Pedro Mártir National Park in Baja California, Mexico at 2,830 m. above sea level, approximately 65 km. east of the Pacific Ocean, 55km west of the Sea of Cortes (Gulf of California) and 180km south of the United States and México border.

The aim of this paper is to provide an update of SPIE paper 9906-84 to identify the changes associated with final design for the site infrastructure, enclosure and support facilities to date and share the design and construction approach.

**Keywords:** TSPM, San Pedro Martir, Mexico, observatory, enclosure, support, mechanisms, pier

## 1. INTRODUCTION

The Institute of Astronomy of the National Autonomous University of Mexico (UNAM) and the Instituto Nacional de Astrofísica, Óptica y Electrónica will be constructing a 6.5m diameter telescope to be located at the National Astronomical Observatory of San Pedro Mártir, Baja California within the Sierra de San Pedro Mártir National Park. Based on the Magellan Telescopes located on Las Campanas, Chile, the TSPM enclosure and support facilities design utilizes the successfully proven functional and space organization layout and adapts the design to project's unique requirements and site challenges. M3 Engineering and Technology Corporation (M3) has provided a Preliminary Design study for the *Telescopio San Pedro Mártir* Observatory (TSPM). This new telescope will join a group of three existing telescopes of smaller diameters (0.84 meters, 1.5 meters and 2.1 meters). The telescope facilities include an enclosure building and a support building connected by an access corridor and bridge on the observation level for telescope related activities.

"The telescope's mechanical design is inspired by the Magellan telescopes in Las Campanas, Chile. However, the primary mirror cell will be completely compatible with the Multiple Mirror Telescope's (MMT) Cassegrain focus. The TSPM will also include Nasmyth focal stations slightly farther from the primary than at the Magellan telescopes to allow a wider field of view. This design is being led by the Centro de Ingeniería y Desarrollo Industrial (CIDESI) in Querétaro,



Figure 1.1 Basis of design: Magellan Observatories, Las Campanas, Chile.

Ground-based and Airborne Telescopes VII, edited by Heather K. Marshall,  
Jason Spyromilio, Proc. of SPIE Vol. 10700, 107002N · © 2018 SPIE  
CCC code: 0277-786X/18/\$18 · doi: 10.1117/12.2309953

Proc. of SPIE Vol. 10700 107002N-1

México. Initially, the telescope is to operate in a f/5 Cassegrain configuration. The specific configurations for the future expansion to other focal stations, including Nasmyth and folded Cassegrain stations, are currently under study.”<sup>3</sup>

## 2. SITE

### 2.1 Location

The site has an average elevation on site of 2,830m above sea level. The National park is located roughly 65km West of the Pacific Ocean and 55km East of the Sea of Cortes (Gulf of California). The existing terrain increases in elevation from North, West, and South, with a peak that rises more than 2,000m from the desert to the East. The highest point in the area of Baja California, is Picacho del Diablo (3,095m), located approximately at 6km south-west of such observatory. The area is located within the interior of a pine tree forest. Most of the area comes with a strong number of rainfall events with clear intervals between. The nearest city is Ensenada (300,000 inhabitants) at 140km to the North. The closest commercial airports are located in Tijuana (at 220 km) and San Diego (250km). There is a 20km paved road leading to the observatory from the National Park’s entrance.



Figure 2.1 Telescopio San Pedro Mártir Location in the Baja California Península



Figure 2.2 Telescopio San Pedro Mártir Site Plan

## 3. BUILDING CODES

The San Pedro Mártir Telescope (Baja California, México) shall consider on its design, the applicable guidelines of the following national and international references:

- International Building Code, Edition 2006
- Occupational Safety and Health Administration (OSHA)
- International Plumbing Code
- International Mechanical Code
- National Fire Protection Association Codes and standards
- International Energy Conservation Code
- National Electrical Code
- Ley de Edificaciones del Estado de Baja California
- Instituto Mexicano del Seguro Social (IMSS)
- Secretaría del Trabajo y Previsión Social (STPS)
- Comisión Federal de Electricidad

## 4. BUILDING LAYOUT

The *Telescopio* San Pedro Mártir Observatory is integrated by two distinguishable building volumes: Enclosure Building and Support Building. The Enclosure Building houses the telescope, telescope pier, while the Support building caters to

telescope related activities, utilities infrastructure and personnel related functions. The two buildings are connected by a bridge that allows for mirror handling, and by an enclosed corridor for both personnel access and utilities.

One of the significant changes from the initial design was to mirror the support building facilities along the axis of the Bridge and Corridor connection to take better advantage of the south exposure.

#### 4.1 Perspective



Figure 4.1.1 Exterior Perspective

#### 4.2 Overall Building Section

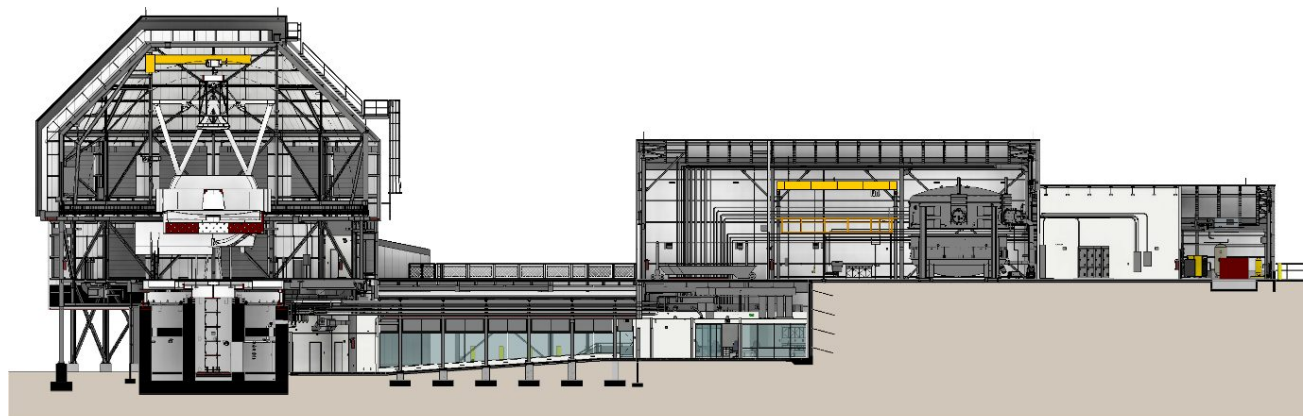

Enclosure Building

Support Building

0m 5 10

#### 4.3 Overall Floor Plans

Figure 4.2.1 Overall Building Section

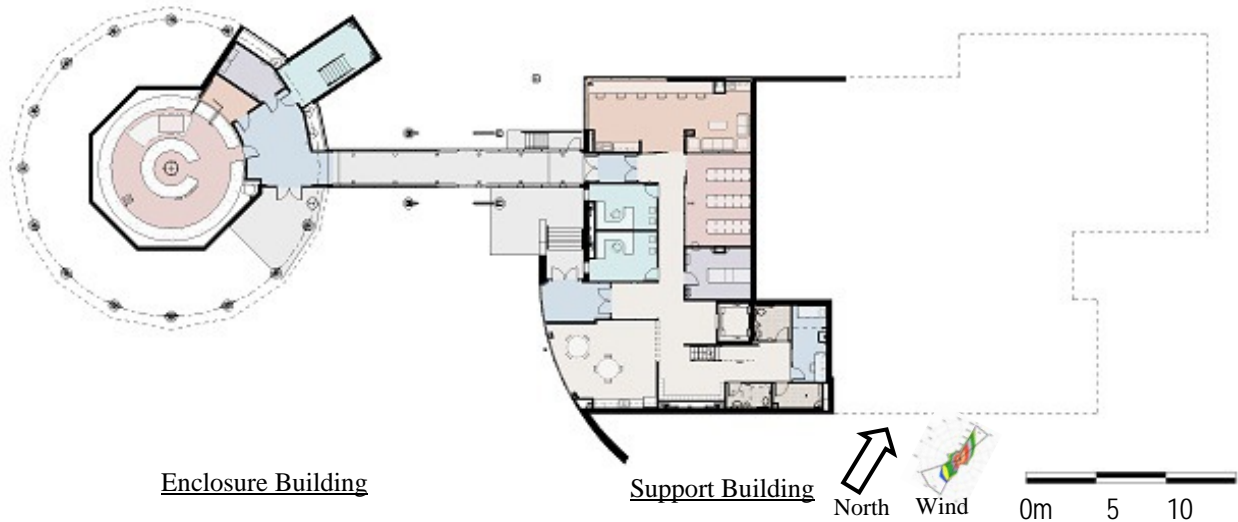

Figure 4.3.1 Overall Floor Plan – Lower Level

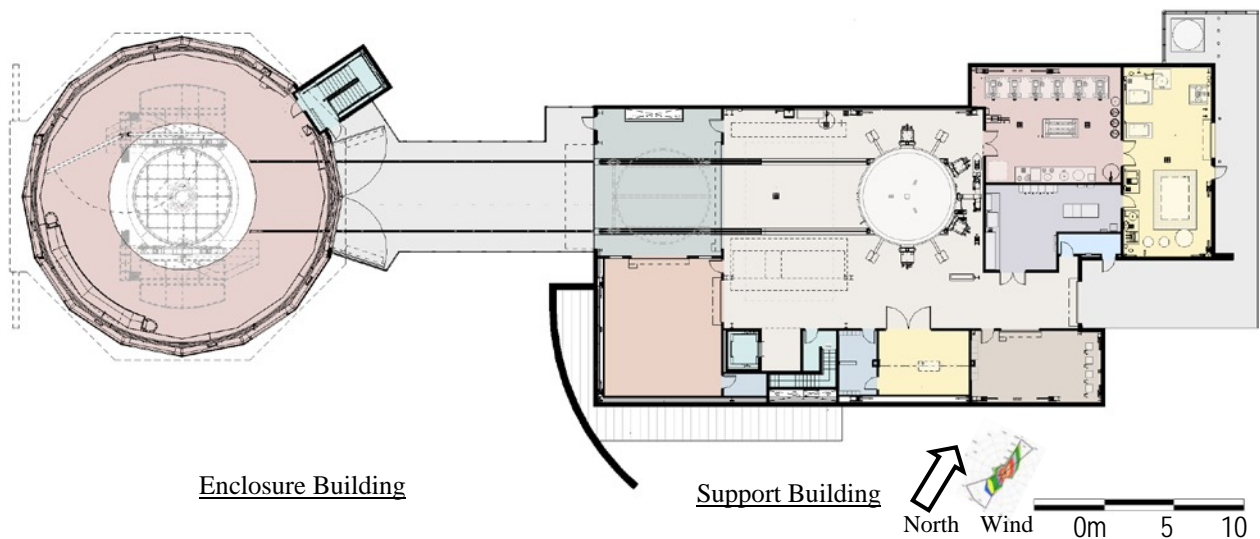

Figure 4.3.2 Overall Floor Plan – Upper Level

## 5. ENCLOSURE BUILDING

### 5.1 Enclosure and Enclosure Base

The Enclosure houses the 6.5 meter TSPM telescope. In the closed position, the Enclosure protects the telescope and its instruments against adverse weather conditions. In the open position, the Enclosure allows the telescope a free field view by means of a large slit in the Enclosure. Also, in this position, the Enclosure provides wind protection, ventilation, and air circulation to create optimum observing conditions for nighttime astronomical observations. The Enclosure is connected to the Support Building using a bridge with embedded floor rails on the observing floor. The rails allow the mirror to be transported to the Support Building for washing and aluminizing.

Equipment at the Enclosure includes a jib crane and a secondary mirror access platform. The 5 metric-ton jib crane is located near the top of the Enclosure and is utilized to lift heavy equipment on the observing floor or to perform telescope maintenance. The secondary mirror access platform is provided to access the secondary mirror for maintenance and is also equipped with a mechanism to remove the secondary mirror if necessary.

The Enclosure Base serves as a foundation and stationary floor for the rotating Enclosure. Along with providing a stationary floor at the observing level, multiple functions are provided at grade level. These functions include an Entrance Lobby, Mechanical equipment, Electrical equipment, and vertical circulation. The design provides accommodations for a future Spectrograph Room capable of housing two optical benches for instruments, and would require a future dedicated HVAC system to maintain a constant temperature.

Materials used for the construction of the TSPM have been chosen for their performance as well as their availability in Mexico. The rotating Enclosure and Enclosure Base are clad with insulated metal wall panels which provide thermal performance and moisture control. The panels consist of a galvanized steel face with polyisocyanurate foam-insulated core. The rotating portion of the Enclosure is faced with adhesive aluminum foil tape, which minimizes emissivity and allows for the optimization of the thermal characteristics of the Enclosure.

Architectural seals are provided between stationary and moving building components. The main function of seals is to protect the interior environment from a wide range of environmental conditions such as water, air, light, and dust. Seals are positioned for ease of adjustment, maintenance, and replacement. Two layers of seals will be provided. The first seal stops high wind, light and most precipitation from entering the building. The second seal keeps out moisture.

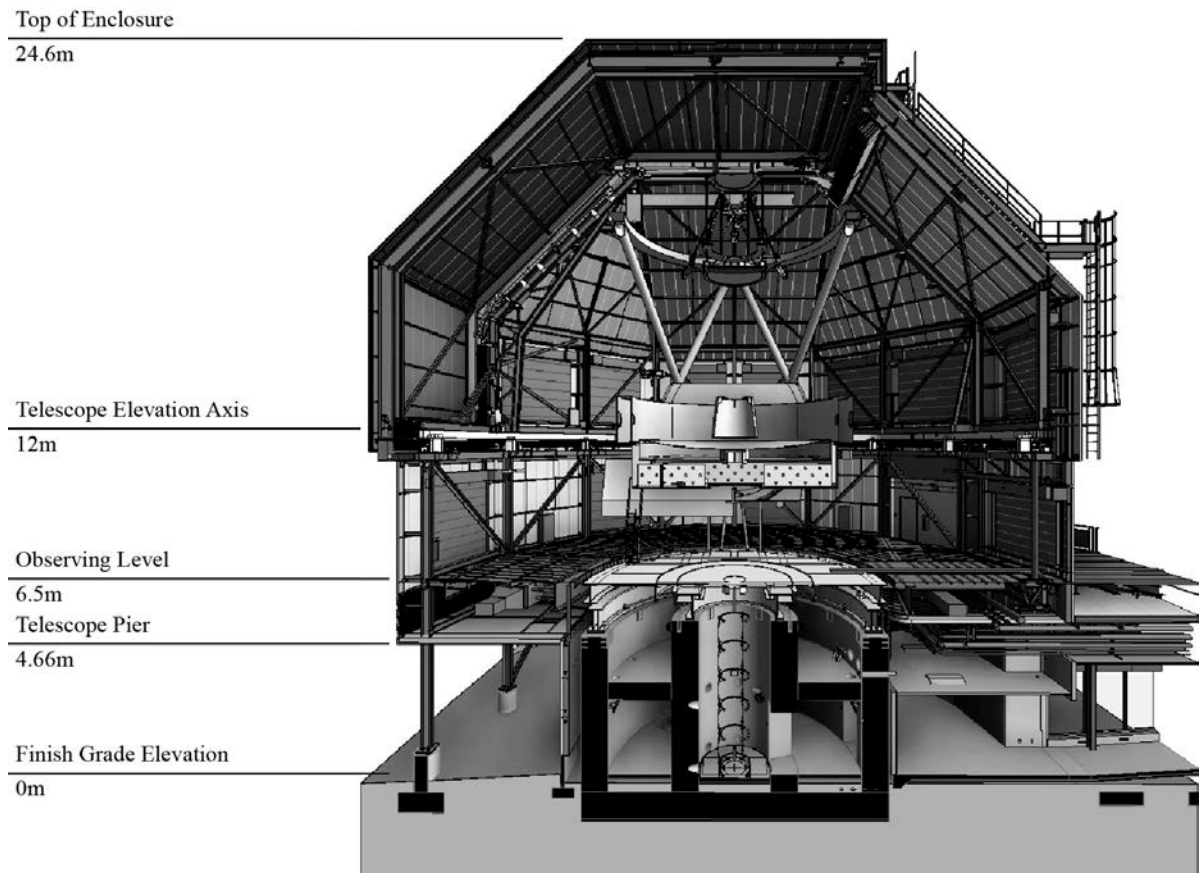

Figure 5.1.3 Enclosure Section Perspective

## 6. SUPPORT BUILDING

### 6.1 Support Building Overview

The support building houses telescope related activities, utilities infrastructure, and personnel related functions and is located adjacent to, and downwind from, the enclosure building. Telescope related activities and the utilities infrastructure are located on the upper level, while personnel spaces are located on the lower level. The support building is connected to the enclosure via the utilization of a bridge with embedded floor rails for the transportation of mirror cell and instruments at the upper level. An enclosed walkway, below the bridge, is also provided for the movement of personnel on the lower level. The support building can be divided into three categories to better understand the functional and space requirements. The three categories are Telescope Related Activities, Utilities and Personnel Related Functions.

Telescope related activities are housed on the upper level of the support building. This level shares the same elevation as the enclosure observing level. This facilitates the movement of mirror cells between the two buildings via a pair of embedded floor rails. Three large bays are provided for mirror washing, mirror coating, and an instrument lab. The first bay is for mirror washing. This bay will include a high bay 27 metric tonne bridge crane with a motorized mirror wash platform below crane to accommodate mirror washing operations. The second bay is for mirror coating, and provides for the permanent placement of a high vacuum sputtering system. This system is used to deposit high-reflectance aluminum films on the primary and secondary mirrors. The third bay provides an open space for instrument assembly and maintenance. A clean room, with vestibule, is also provided adjacent to this bay. A 4 metric tonne monorail is provided in the clean room to accommodate material transport of large instruments. To support the washing and coating activities, a dedicated room is provided to house equipment and controls for these activities.

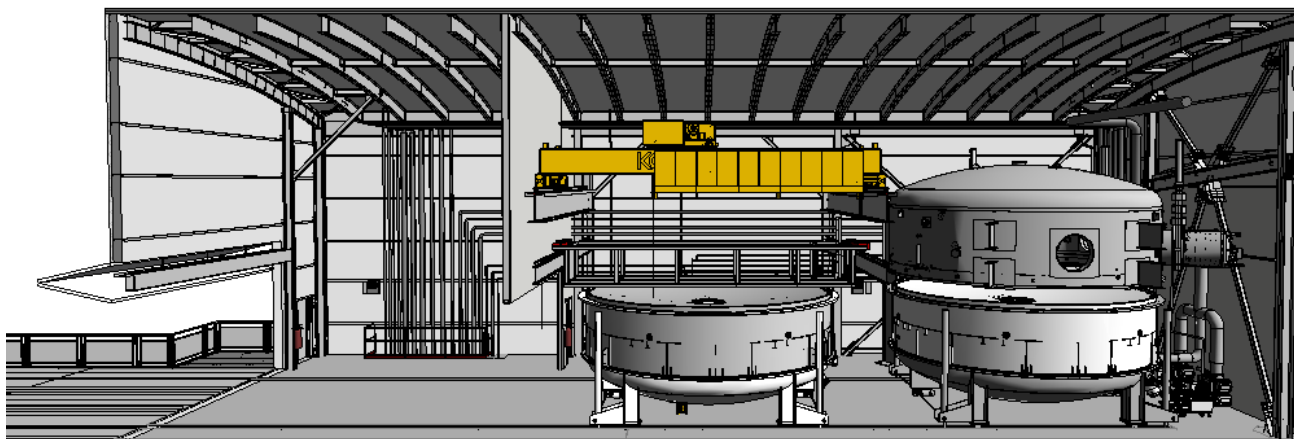

Figure 6.1.1 Section of Mirror Washing and Vestibule Area

The utilities infrastructure for the entire site is located on the upper level of the support building. Dedicated rooms are provided for telescope and Owner furnished equipment, mechanical equipment, and electrical equipment. These spaces are located as far as possible from the Enclosure to reduce heat and vibration that would be detrimental to telescope operations. Ancillary space is also provided for tool storage, a janitor's closet, and miscellaneous storage. Exterior to the utility spaces, and further downwind, is the exterior mechanical and electrical equipment which includes the electrical service entrance, transformer, switchgear, and fluid coolers.

Personnel related functions are housed on the lower level of the support building. These spaces are those frequently occupied by TSPM staff and astronomers. An open control room with countertop space is provided near the access corridor to the enclosure and provides windows for views directly to the enclosure. Supporting the control room is the computer room. The computer room will store the astronomers' data and is supported by an independent cooling system specifically designed to promote air movement around the computer racks. The space will be designed with maximum flexibility to allow ease of expansion and future modifications. Observers will also have a dedicated lounge space with a small kitchenette and tables for eating and/or conference functions. Two private offices will be provided along with other ancillary spaces such as a health room, toilets, IT room, and a storage room. Vertical circulation to the upper level of the support building is provided via stairs and elevator.



Figure 6.1.2 Perspective of Support Building

Access to the enclosure is provided through an enclosed walkway that provides personnel with a protected space to move between the two buildings in the event of a storm or detrimental weather conditions. Louvers and dampers have been added above glazed storefront along both facades of the Enclosure utility corridor to accommodate natural ventilation.

## 6.2 Design Perspectives

Bridge Structure connection

between Enclosure and  
Support Building

Utility Routing above  
ceiling/ soffit of Corridor

Louver and Dampers for  
Corridor Ventilation

Insulated Glass  
Storefront

Ramp connection  
between Enclosure  
and Support Building

Low Level  
Floor Lighting

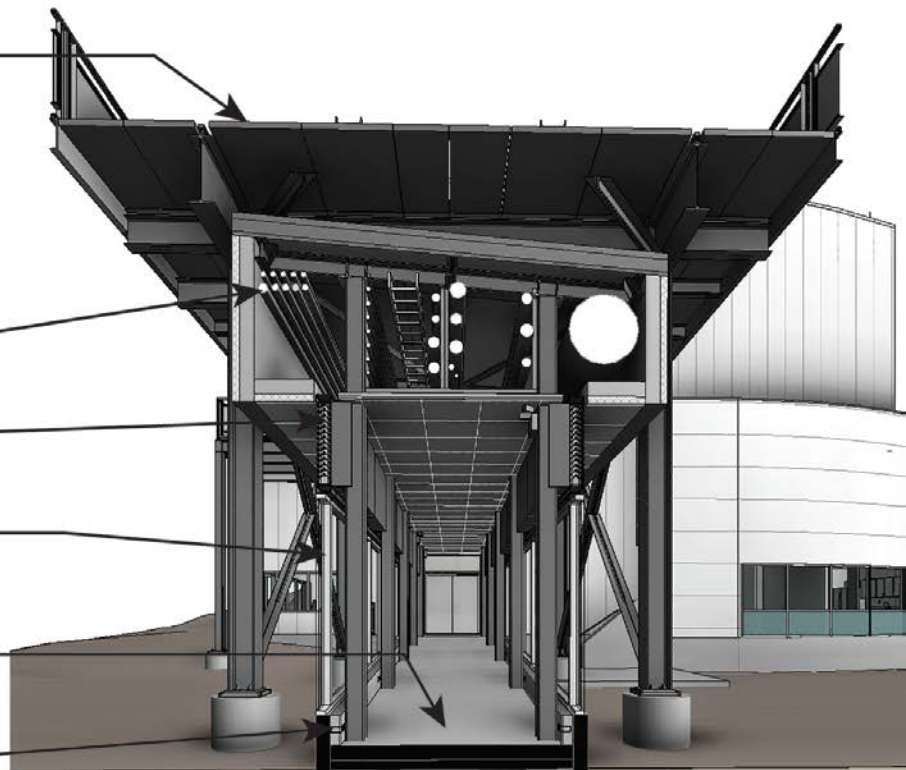

Figure 6.2.1 Support Building Enclosure Access Corridor showing utility coordination.



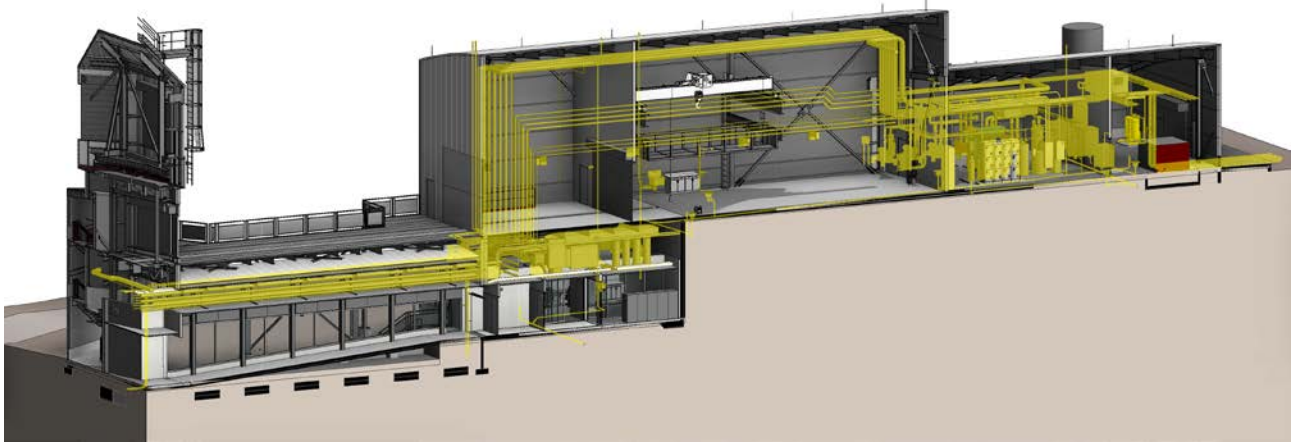

Figure 6.2.2 Utility Coordination between Enclosure and Support Building



Figure 6.2.3 Perspective of Enclosure with Shutters and Ventilation Doors open



Figure 6.2.4 Perspective of Enclosure with Support

## 7. PROJECT STATUS

The project Preliminary Design Review (PDR) was in October 2016. The design was developed further and Critical Design Review (CDR) was completed in November 2017. The design is progressing toward final design with anticipated completion in late 2018.

M3 and Unisystems visited Discovery Channel Telescope (DCT), Space Surveillance Telescope (SST) New Mexico, Gemini South, SOAR, and Magellan facilities to study Plumbing/ HVAC, Electrical, Mechanisms, and RAMS (Reliability, Accessibility, Maintenance, and Safety). M3 incorporated lessons learned from these site visits and site data gathered to improve design for various systems including Windscreen, Moon Roof, Azimuth Mechanisms, Chilled Water systems, and general improvements to maintenance access. These lessons learned items were used to inform and improve the CDR and Final design.

There were various changes to the facility to improve the site design. The support building was mirrored along the bridge corridor axis to take better advantage of solar orientation and to help with snowmelt at entrance area. A nitrogen tank was added at north east corner of building. The domestic water and chemical holding waste tanks were centralized to utilize common excavation. Heat tracing has been added to exterior concrete aprons to deal with snow accumulation.

There were various building updates to improve the facility design and systems. The enclosure access corridor connecting the Enclosure and Support building size and configuration was enlarged to accommodate overall quantity of utilities. The utilities were strategically grouped to maximize efficient routing and access for maintenance. The corridor design changed to accommodate addition of operable louvers and dampers above glass storefront to facilitate natural ventilation. The skirt of the Fixed Based enclosure was modified to add continuous band of louvers around perimeter to facilitate ventilation of the space below Observing Level. There was close supervision of design to ensure that utility interfaces with cranes and other moving equipment was accommodated. The design of utilities and routing was closely coordinated at fixed based to pier interface to accommodate vibration isolation separation. We continue working on

multiple BIM models coordinated throughout process of design to ensure coordination among utilities and building elements. The design has progressed to incorporate many of the Telescope and Instrument interfaces still pending at the previous design phase.

## 8. ENCLOSURE STEEL DESIGN

The Enclosure and Enclosure Base are designed using a steel structure, maintaining similar geometry to that reported in 2016 with some upgrades that the respond to the system and building updates discussed on section 7 as well as site specific updated information, specifically the seismic accelerations.

The seismic accelerations were revised by a recent seismic hazard analysis performed by the Geotechnical engineer in response to a reevaluation of the seismic return period of the project. This represented approximately a 30% increase in seismic base shear compared to that one used in 2016. This represented a reorganization of steel components and addition of structural elements to provide an optimal load path, both vertically and laterally. Furthermore, the seismic response factor was modified to  $R=1.5$  to capture the seismic behavior that the mechanisms at the Azimuth rotation interface will exhibit.

The structural analysis and design of TSPM incorporates a coordinated analysis with the mechanisms design to ensure coordinated interfaces, matching detailing and ensuring required performance.

In addition, the Enclosure steel structure incorporates the relocation of the jib crane to a lower position that allows a wider reach within the interior envelope of the Enclosure. See Figures 7.1 and 7.2 for examples of the structural analysis rendering.

The design of the steel structure has been further advanced by developing connections of the structure itself, interfaces with the mechanisms, and mechanical ventilation system updates including those noted in section 7.

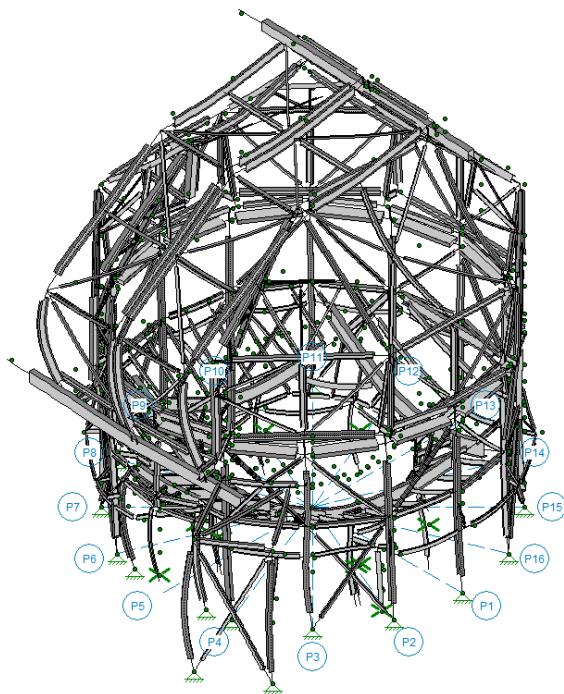

Figure 7.1 – Enclosure and Enclosure Base Model, Deformation under Dead+.75Wind+.75Live+.75Snow” Load Combination. (Magnified a factor of 40, the dots shown represent the structural joints in the undeformed state as a benchmark to graphically identify deformations)

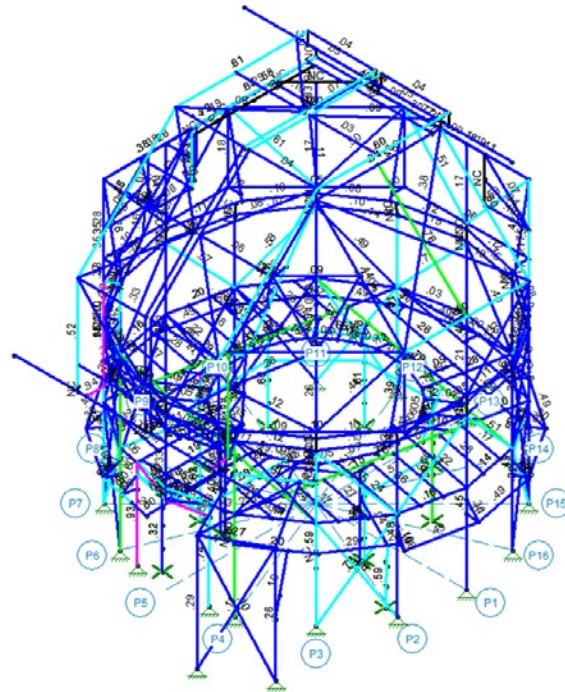

Figure 7.2 – Enclosure Model Envelope of the Bending Stress Ratios on members.

## 9. TELESCOPE PIER

The Telescope Pier geometry has been updated below grade and analyzed for the updated seismic accelerations described in the previous section. The rest of the geometry has had very few changes to that reported in 2016.

In response to updated geotechnical properties, the base elevation of the Telescope Pier has been raised 1.5 m and a concrete mat foundation added. The reduction in excavation alleviates the expense and effect on the existing rock while the mat foundation maintains the pier stiffness and stability. Additional minor modifications have been incorporated to the pier in order to provide utilities access and Telescope interface. However, the overall dimensions of the Pier above ground have been maintained. See Figure 8.1 for a rendered representation of the current Telescope Pier.

The Telescope Pier model has been analyzed in a similar manner to that presented in 2016, using a volumetric finite element model to determine the frequencies and dynamic modes, including a set of springs to represent the soil-structure boundary condition and a set of eight highly-rigid and mass-less bars to represent the link between Telescope and Pier. These bars have the releases to transfer the forces to the concrete walls as described lines above. See Figure 8.2 for a pictorial of the Finite Element Model used.

Based on the current geotechnical report, the dynamic modulus of elasticity varies with depth at different strata under the pier location. These values have been combined using a harmonic average and using an upper and lower bound approach. The upper bound value is that obtained directly from the values reported whereas the lower bound value considers that there will be a 20% degradation in the dynamic modulus of elasticity due to site preparation operations. The frequencies obtained from the dynamic analysis are presented on Tables 8.1 and 8.2. These values are much higher than those reported in 2016, given that the dynamic moduli values have improved considerably as well as the introduction of a mat slab foundation described above. In addition, the lower and upper bound moduli values (13.4 and 16.8 GPa) seem to have little effect on the frequencies obtained. Finally, the stiffness and mass moment of inertia of the Telescope will have influence in the dynamic behavior of the Pier. These values are expected to be incorporated as the Telescope design is advanced in the following stages.

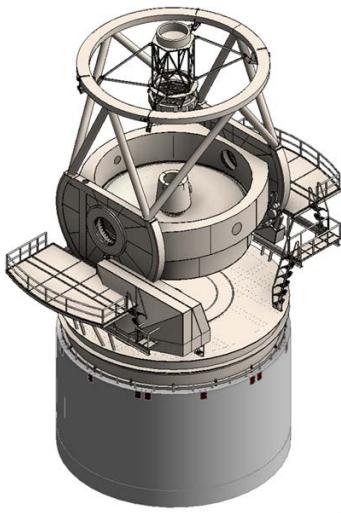

Figure 8.1 – Telescope Pier Model Isometric.

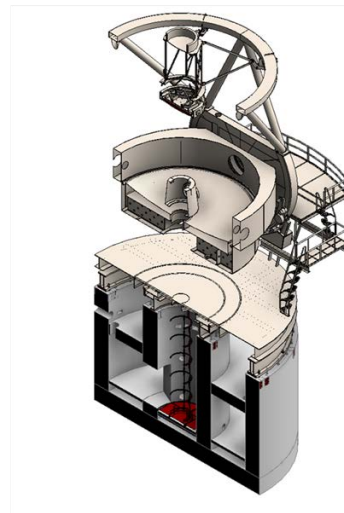

Figure 8.2 – Telescope Pier Model Finite Element Model Isometric.

Table 8.1 Frequencies for case with Modulus of Subgrade Reaction of 16.8 GPa

Mode	Frequency (Hz)	Period (Sec)	Mass Participation		
			SX	SY	SZ
1	15.79	0.06	47.21		7.20
2	15.96	0.06	7.60		46.00
3	37.71	0.03		53.80	0.04
4	45.24	0.02	21.43		0.50
5	46.53	0.02	0.04	0.03	28.05
6	47.72	0.02	5.91		0.72
7	77.95	0.01		41.18	
8	81.72	0.01			
9	86.37	0.01	6.99		
10	88.14	0.01			9.29
11	90.35	0.01		0.12	0.34
12	93.36	0.01			0.17
13	106.20	0.01	7.13		0.07
14	107.18	0.01	0.30	0.04	4.13
15	113.00	0.01	0.17		0.43
16	114.25	0.01			
17	115.84	0.01	0.03	0.05	
18	122.27	0.01	0.79	0.02	0.05
19	126.06	0.01	0.01		
20	128.22	0.01		0.62	0.19
Totals:			97.64	95.88	97.21

Notes: Based on 16.8 GPa modulus of elasticity (E) and considering outer pier supports axial (vertical) forces, while inner pier supports radial (horizontal) forces. Bottom of Pier is considered to be 1.5m below grade.

Table 8.2 Frequencies for case with Modulus of Subgrade Reaction of 13.4 MPa

Mode	Frequency (Hz)	Period (Sec)	Mass Participation		
			SX	SY	SZ
1	15.12	0.07	49.24		6.51
2	15.27	0.07	6.84		48.12
3	36.91	0.03		57.98	0.05
4	43.40	0.02	7.60		0.04
5	44.76	0.02	13.14	0.02	9.52
6	45.26	0.02	6.84	0.02	19.76
7	73.81	0.01		38.30	
8	80.83	0.01	3.51		0.03
9	81.33	0.01	4.72		0.23
10	82.61	0.01	0.02		10.13
11	86.49	0.01		0.14	0.10
12	92.81	0.01			0.09
13	102.21	0.01	6.04		
14	104.68	0.01		0.02	3.30
15	112.04	0.01	0.08		0.08
16	112.74	0.01	0.03		0.10
17	115.65	0.01	0.01	0.04	
18	120.81	0.01	0.41	0.02	0.02
19	123.32	0.01			0.01
20	127.50	0.01		0.50	0.13
Totals:			98.51	97.05	98.23

Notes: Based on 13.4 GPa modulus of elasticity (E) and considering outer pier supports axial (vertical) forces, while inner pier supports radial (horizontal) forces. Bottom of Pier is considered to be 1.5m below grade.

## 10. MECHANISMS

### 10.1 Mechanisms Design Philosophy

The baseline designs for the *Telescopio* San Pedro Mártir (TSPM) mechanisms are those utilized in the Magellan 6.5 Meter Telescope Project (Magellan). The Magellan designs are, by and large, successful precedents with simple arrangements that incorporate industry standard construction details. Modifications to the original Magellan designs were made only in the following instances:

- Where analysis evinced load path inadequacies for the environmental loads unique to the TSPM site.
- Where analysis and operational experience of the Magellans indicated lower-than-desired reliability, accessibility, maintainability, or safety (RAMS), with an economical means of remediation.
- Where obsolescence of components required new component selection.

To this end, detailing of TSPM mechanisms has its basis in two sources of input. First, a trip to the Magellans was taken in which the operational characteristics of the mechanisms were observed and in which the maintenance staff provided input as to the experiential reliability, accessibility, maintainability, and safety of the baseline design. Second, detailed calculations were performed in which all mechanisms were rigorously studied under the influence of anticipated loads.

### 10.2 Azimuth Rotation Mechanisms

#### 10.2.1 Design Requirements

Azimuth rotation mechanism design requirements remain largely unaltered from the PDR design phase; refer to [2].

#### 10.2.2 Mechanism Layout

The azimuth rotation mechanisms consist of 16 equidistantly spaced bogie assemblies mounted to the fixed structure of the enclosure at each of the 16 column locations. Every fourth bogie is equipped with a drive, for a total of 4 equidistantly spaced drive bogies. Every bogie assembly is accompanied by a secondary restraint assembly consisting of a stanchion, 2 lateral guide rollers, and 1 uplift clip, for a total of 32 lateral guide rollers and 16 uplift clips.

#### 10.2.3 Bogie Design

Each bogie assembly consists of a welded, machined, and bolted wheelbox that holds the bogie wheel, shaft, and a pair of bearings. This wheelbox is connected to a secondary weldment with two semi-flexible elements: a pair of Fabreka spring blocks, which provide a compliant path for vertical loads, and a steel flexure plate, which provides a stiff load path for lateral loads while allowing for tilt to accommodate rail twist. Adjustment blocks and jack screws are provided on the bogie base weldments for precise alignment and positioning of bogie wheels, drive units, and restraints to required tolerances.

The four drive bogie assemblies are identical to the idler bogies for ease of maintenance but also include 5.6 kW (7.5 hp) helical-bevel gearmotor units, each driven by their own VFD. These gearmotors are largely identical to those specified for the Magellans, which the maintenance staff has stated can allow for azimuth rotation even with 2 of the 4 drive units entirely removed for maintenance. Each gearmotor unit is provided with a fail-safe brake to arrest dome rotation; these brakes engage automatically in case of power failure. A drive bogie and its details are shown in Figure 10.2.3.1.

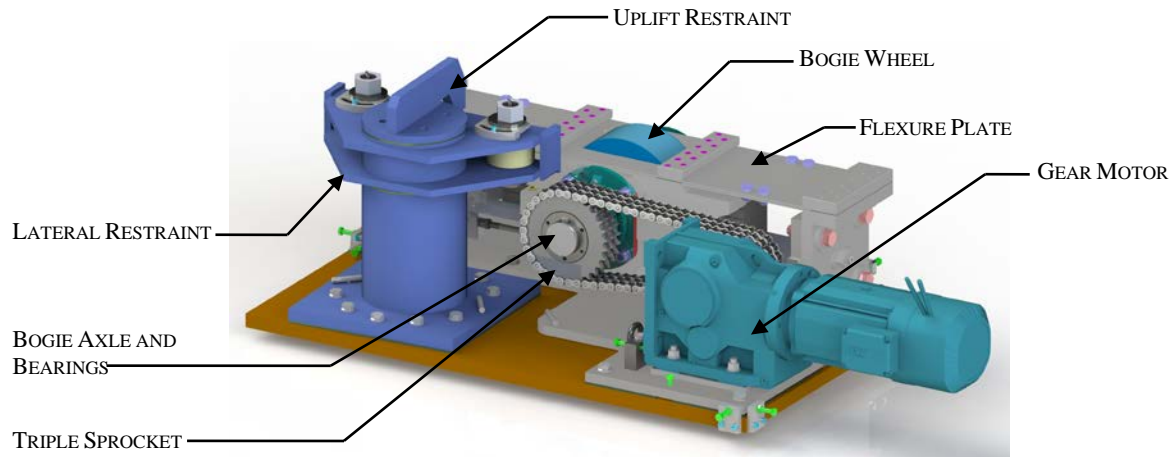

Figure 10.2.3.1 Azimuth Drive Bogie

#### 10.2.4 Magellan Bogie RAMS Assessment

In general, the reliability, accessibility, maintainability, and safety of the Magellan azimuth bogie assemblies have all been fairly good, with a few minor exceptions.

On the positive side, the following characteristics were observed: 1) A reasonable level of vertical compliance was provided in the design, creating a favorable level of load sharing between all bogie assemblies; 2) Well-designed adjustment features were incorporated, facilitating alignment following bogie swapping for maintenance activities; 3) There is open access to all bogies, with a baseplate adequately sized to extract the bogie from beneath the rail before hoisting; and 4) The flexure plate provides a stiff path for lateral loads near to the wheel-rail interface while largely releasing the bogie torsionally, which accommodates consistent wheel-rail contact with a non-crowned wheel. This last feature, in particular, has led to excellent wheel-rail wear characteristics, with roughly 0.1mm of wear measured on the track after nearly two decades of use

On the negative side, the greatest shortcoming of the Magellan bogie is an inadequate load path from the wheel to the wheelbox for lateral loads, which are an inevitable result of rolling contact due to creep forces that arise from steering misalignments between the wheel and the rail. This has led to two deleterious consequences: 1) Premature failure of the spherical bearings, leading to an increased level of maintenance (as much as once per year per rotating enclosure), and 2) Slippage of the wheel on the shaft and/or slippage of the shaft in the bearings such that the wheel begins rubbing and grinding against the edge of the flexure plate. The vulnerability of the Magellan bogie to these failure modes was corroborated by analysis.

#### 10.2.5 TSPM Bogie Updates

To remedy the observed shortcomings, the TSPM axle and bearings include several modifications to the baseline design. First, one of the spherical bearings has been replaced by a tapered roller bearing capable of absorbing lateral loads. Second, direct load paths have been created between the wheel and the tapered roller bearing through the utilization of 1) a thrust washer for a direct compressive load path on one side of the wheel, and 2) a shaft collar on the opposite side of the wheel coupled with a bearing locknut on the outboard side of the tapered roller bearing. Third, an expansion-type spherical bearing is used to further ensure that thrust loads transfer through the tapered roller bearing instead of the spherical bearing. Refer to Figure 10.2.5.1 for a cross-section of these details.

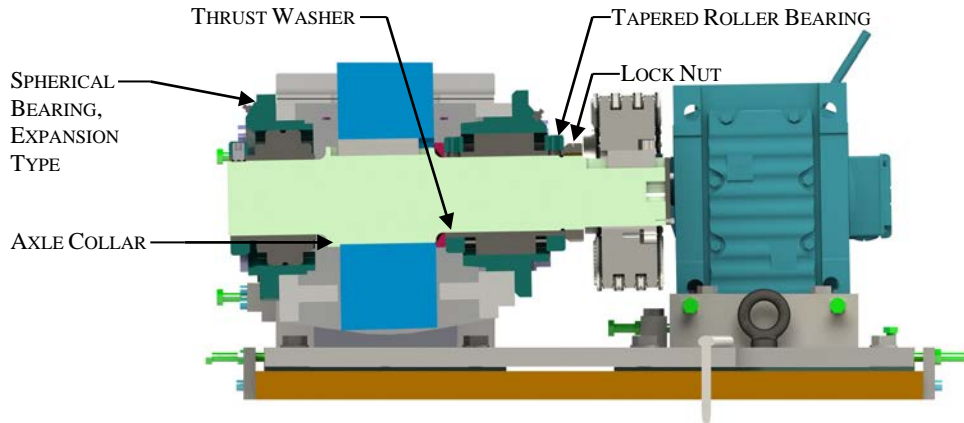

Figure 10.2.5.1 Azimuth Bogie Bearing Arrangement

These changes were incorporated without a change in the wheel size, axle diameter, or wheelbox size. The tapered roller bearing and expansion-type spherical bearing are virtually identical in cost to the original spherical bearings and remain standard purchased parts.

### 10.2.6 Uplift and Lateral Restraints

A stanchion weldment bolted adjacent to each bogie provides mounting locations for an uplift clip and a pair of lateral restraint rollers (visible in Figure 10.2.3.1). Due to differences in environmental loading and feedback from the Magellan maintenance staff regarding reliability, several changes have been incorporated into the TSPM design while preserving the overall arrangement.

First, on account of increased survival-level lateral loads, arising from high seismic requirements for the TSPM site, the stanchion weldment was increased in capacity and a rotational release was added to share load between the two rollers. A round hollow steel section was selected that maintained a similar size to the original built-up steel I-beam.

Second, on account of a reduction in survival-level uplift loads (to the point that no uplift is expected even under worst-case wind conditions) the uplift roller was replaced with a simple steel clip. This would lead to steel-on-steel contact in the unexpected event of uplift but removes a mechanical component from the assembly.

Third, on account of semi-regular failure of lateral guide rollers in the Magellans, the yoke-style cam follower has been respecified from a needle bearing, which has very little thrust capacity, to a tapered roller bearing, which comes with a defined load path for the thrust loads that arise from lateral creep forces and from scrubbing that occurs during vertical travel of the track.

## 10.3 Windscreen

### 10.3.1 Design Requirements

The windscreen complies with the following specifications:

- Travel speed of 0.36 degree per second (0.36 °/sec) relative to the project origin
- Height of deployment of 9.6 m above the elevation axis
- Wind speeds
  - Maximum operational wind speed of 50 kilometer per hour (31 mph)
  - Maximum operational gust wind speed of 70 kilometer per hour (44 mph)

### 10.3.2 General Layout

The windscreen protects the telescope from winds that could lead to telescope jitter during observations. The windscreen consists of 20 folding aluminum panels adjoined by steel hinges. Rollers at either end of every panel follow the paths of two parallel steel tracks, the layout of which largely matches the piecewise linear path of the enclosure arch girders. The relative offset between the two parallel tracks forces the panels to assume a rigid zig-zag pattern once deployed.



Lift chains along each side attach to the lead panel and drive the unit between the stowed and deployed positions. The chains are connected to a common jackshaft that is driven by a single gearmotor. Chain tensioners keep consistent tension on the chains during operation. An absolute encoder provides position information, and inductive limit switches provide homing feedback for the end of travel in both the stowed and fully-deployed positions.

When stowed, the panels fold into a stack at the base of the rotating enclosure, located between the azimuth bogie assemblies and the lower portion of the shutter doors. When fully deployed, the panels extend to an elevation 9.6 m above the elevation axis. See the Figure 10.3.2.1 for windscreen component details.

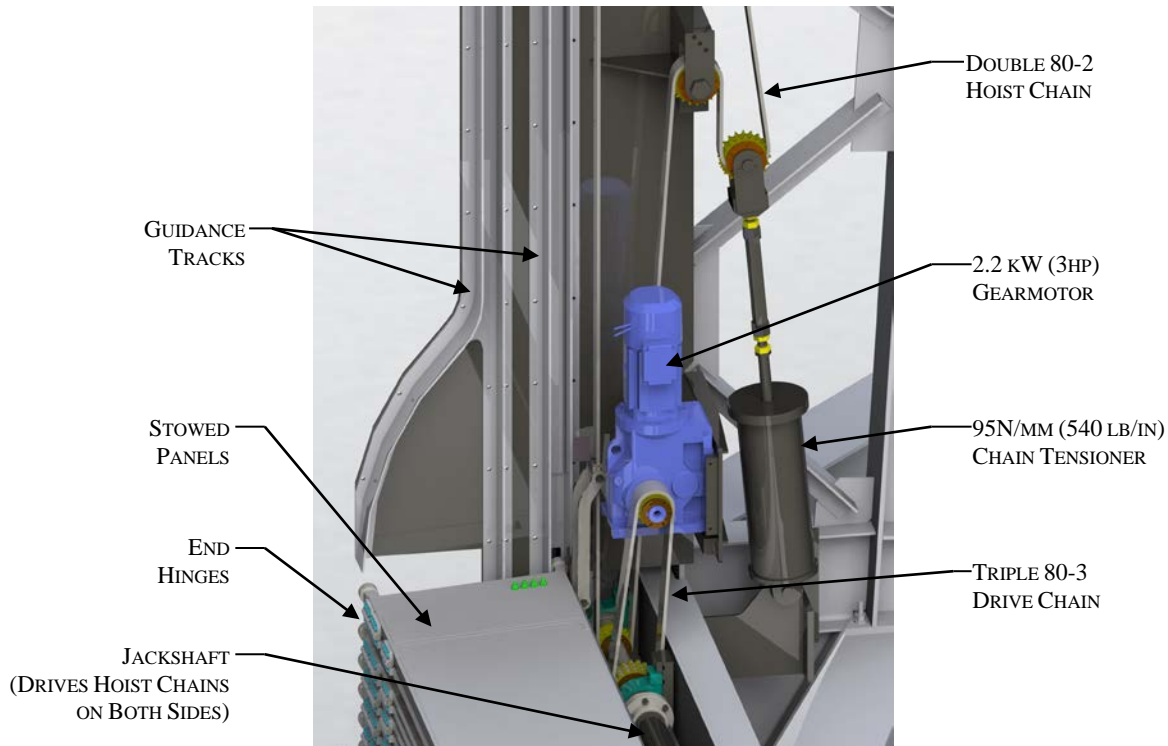

Figure 10.3.2.1 Windscreen Components

### 10.3.3 Magellan RAMS Assessment

Unlike the other Magellan mechanisms, the windscreen has had a checkered history of performance; the Clay observatory windscreen has proven relatively reliable, whereas the Baade observatory windscreen has exhibited such severe vibration problems during operation that it has gone relatively unused during the lifetime of the project. As such, the windscreen received the highest level of scrutiny during the design and development of the TSPM mechanisms, both during the site visit to the Magellans and during the analysis phase.

Observing ammeter outputs and the visual behavior of the chains and sprockets – both on site and in subsequent analysis of video – led to the conclusion that the deleterious vibrations during operation are dominated by stick-slip behavior, likely due to the combined effect of myriad binding and friction forces. In support of this hypothesis is the observation that all dynamic behavior, including vertical oscillations of the panels and jerky motion of the sprockets, occurs at a frequency of roughly 3.1 Hz, which coincides with the frequency at which the roller chain engages with the sprocket teeth. Although the vibrations were noticeably more violent during operation of the Baade windscreen, this same behavior (with a 3.1 Hz dominant frequency) was observed during operation of both the Baade and the Clay windscreens. Furthermore, both site measurements and structural analysis have confirmed that the lowest structural resonances of both windscreen panel types are significantly above the chain cogging frequency.

### 10.3.4 TSPM Updates: General Approach

In light of these observations, particularly the fact that both the Baade and Clay windscreens suffer from similar root problems (albeit to different extents), the TSPM windscreen was reengineered with the following approach:

- The baseline architectural layout was preserved without modification, including hinge points, roller offsets and diameters, track locations, and deployment path.
- Where economically viable, all potential sources of binding and drive resistance were aggressively mitigated.
- The structural load path was redefined intentionally and deterministically such that all remaining sources of binding and drive resistance could be analyzed and quantified with a higher degree of certainty. In particular, heightened attention was given to the lateral load path necessary to transfer global creep forces, which appear to have been unaccounted for in the baseline Magellan design.
- Consideration to constructability, including allowance for reasonable fabrication tolerances and their effects, was included explicitly in the analysis approach.

### 10.3.5 TSPM Updates: Representative Example

The detailing of nearly all components was revised to incorporate the above considerations. While the full extent of updates is beyond the scope of this document, the modifications to the hinges will be highlighted as a representative example.

Piano hinges were used in the Magellan windscreens and run either continuously across the entire hinge line (Clay) or as a mix of continuous and intermittent hinge lines (Baade). The following potential shortcomings were observed. First, hinge knuckles nearest the rollers are potentially undersized and over-utilized; this may lead to connection slippage or component deformations that exacerbate binding concerns. Second, hinge knuckles over the interior 90% of the panel are potentially oversized and under-utilized, leading to weight inefficiencies. Third, indeterminacy for lateral loads may lead to binding and hinge-knuckle rubbing (by forcing composite action between adjacent panels as they deform under their own weight). Fourth, hinge pins occasionally work their way out and must be monitored. Fifth, the continuous nature of the hinges makes it difficult to ensure proper lubrication, with steel-on-steel rotations further adding to drive resistance.

To obviate these issues in the TSPM windscreen, multiple design modifications have been made to the hinges. First, two types of hinges have been incorporated: stouter, stronger hinges for the panel ends, where radial loads are the highest, and longer hinges optimized for thrust loads at the midspan and quarter points; reference Figure 10.3.2.1 for view of the stouter end hinges. Second, all hinges have clearance gaps between their knuckles to eliminate indeterminate load paths that may induce binding, with the exception of the midspan hinge (into which low-friction Duralon thrust washers have been inserted to intentionally carry thrust forces at a low-radial-load location). Third, all hinges incorporate Duralon sleeve bearings to create a maintenance-free, low-friction surface for rotation. Fourth, all pins have been secured with snap rings to prevent pins from working their way out. Fifth, all hinges have been designed with slip-critical connections to the aluminum panel to safeguard against movements that could lead to out-of-tolerance behavior during deployment.

Similarly motivated updates were made to the windscreen rollers, studs, slide pads, panels, tow arms, chain sprockets, and mechanism assembly procedures, in a concerted effort to ameliorate the vibration and performance issues discovered during the on-site RAMS assessment of the Magellan windscreens.

## 10.4 Moonroof

The moonroof protects the telescope from stray light during observations. The moonroof is located in the roof of the enclosure structure within the observation opening. When not in use, the moonroof folds and stows in a dedicated recess at the back of the observation opening, beneath the upper shutter beam.

The moonroof construction, form, and mechanization are all similar to those of the windscreen. However, because the moonroof moves horizontally rather than vertically, drive loads, roller reactions, and hinge loads are all substantially reduced compared to those in the windscreen. Correspondingly, the Magellan moonroofs have been largely reliable.

Even though load demands are less, commonality of parts between the moonroof and the windscreen is sought where practical to minimize components and streamline maintenance activities. Refer to Figure 10.4.1 for the basic layout of the moonroof.

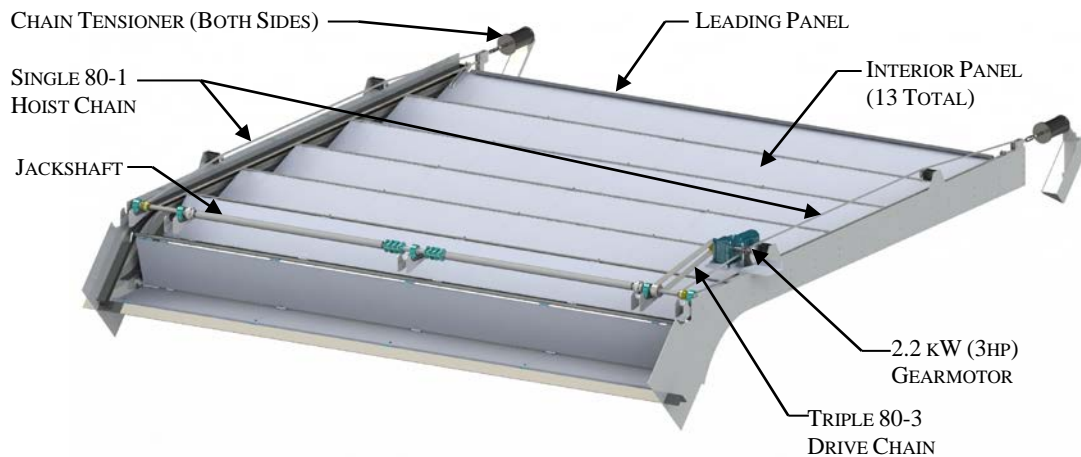

Figure 10.4.1 Moon screen Components

### 10.5 Shutter Mechanisms

Per the Magellan maintenance staff, the shutter mechanisms have exhibited a high degree of reliability. The primary concerns expressed by the maintenance staff were both related to the lateral guide rollers. First, the bearings in the lateral guide rollers had failed on multiple occasions, requiring replacement. Second, when these lateral guide rollers had to be replaced, jacking of the shutters was required to unload the rollers (the self-weight of the shutters pushes the inboard guide rollers against the shutter beam rails), and there was no convenient way to do so. Other than addressing the concerns related to the guide rollers, no significant modifications to the layout or approach of the baseline design have been incorporated in the design for the TSPM shutter mechanisms. Refer to [2] for more details.

### 10.6 Enclosure Thermal Control System

The TSPM will utilize both active and passive thermal control systems to ensure optimum observing conditions. These conditions are ensured when the surfaces of the telescope and enclosure have a temperature identical to the ambient nighttime observing temperature. Active thermal control systems include air conditioning the inner volume of the closed Enclosure during the daytime to the predicted nighttime opening temperature. Passive thermal control systems include reducing the daytime heat input through the utilization of insulated wall panels and architectural seal systems.

The active air conditioning thermal control system, see figure 10.6.1, will consist of multiple fan-coil units placed on the underside of the Enclosure observing level floor. Conditioned air will be ducted from the fan-coils through the observing level floor into the Enclosure. The ducting will be arranged in a manner to encourage homogenous mixing and minimum temperature stratification within the Enclosure. The fan-coil units will use chilled water supplied from outside the building and no heat from the units will be dissipated into the Enclosure. Based upon the system sizing calculations performed for the TSPM, four units having a nominal capacity of 11.6 kW (3.3 tons) each may be provided to achieve proper thermal control.

The fan-coil units will be served with a low-temperature chilled water solution (also known as “brine”) circulated from a chiller located in the Support Building. The brine will be a 50 percent mixture of propylene glycol and water. The non-toxic nature of Propylene glycol is preferred over ethylene glycol for environmental reasons. The chiller will need to provide brine at a temperature low enough to maintain the enclosure at the anticipated evening opening temperature. In the winter season the brine temperature may need to be as low as  $-15^{\circ}\text{C}$  to maintain the air temperature at the  $-2^{\circ}\text{C}$  design point. To do this a special low temperature chiller will be needed. The low temperature chiller will be cooled by  $7.2^{\circ}\text{C}$  chilled water from the air cooled chiller that also provides chilled water to the building.

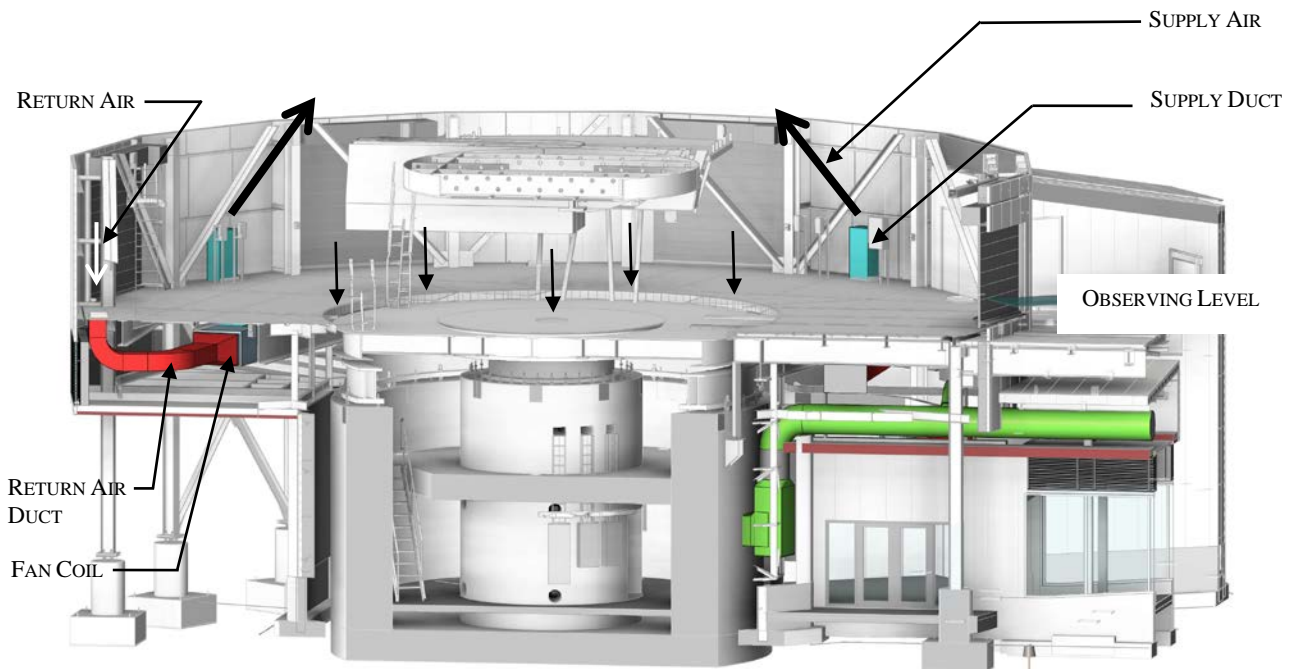

Figure 10.6.1 Enclosure Fan Coil Profile Section

The passive thermal control systems will consist of insulated metal wall panels and architectural seal systems to reduce daytime heat input. The insulated wall panels consist of galvanized metal skins with foamed-in-place polyisocyanurate insulation. The joints are tongue and groove with interlocking rain screens to provide air tightness, low thermal bridging, and high thermal performance. Architectural seal systems protect the interior environment from a wide range of environmental conditions such as water, air, light, and dust. Two layers of architectural seals will be provided at all locations, reducing outside air infiltration.

A cooling load evaluation was performed for the TSPM. The Enclosure was modeled in Carrier's HAP (Hourly Analysis Program) software to evaluate the cooling load due to environmental effects. A 75mm thick panel will be used as the basis-of-design. The manufacturer's overall R-value was derated by 17% to account for some thermal bridging at fasteners and joints. The 75mm thick insulated wall panels are listed by the manufacturer as having an Rsi-value of 1.3 / 25mm, or Rsi-3.9 in the case of 75mm panels. This value was derated to Rsi-3.0 for the purposes of calculating the cooling loads. The 100mm thick insulated roof panels are listed by the manufacturer as having an Rsi-value of 4.2. This value was derated to Rsi-3.5 for the purposes of calculating the cooling loads. The dome cooling load was estimated to be 45.6 kW, or 13 tons of cooling delivered.

Note that these values are calculated loads. Nominal equipment capacities will be higher, as the equipment must be derated for service at altitude, to account for motor heat and brine heat transfer properties.

### 10.7 Enclosure Ventilation

During nighttime viewing, the Enclosure will be ventilated to optimize observing conditions. Ventilation will be accomplished through ventilation doors on the Enclosure walls, allowing the Enclosure volume to be continually ventilated and flushed with nighttime temperature air. The ventilation doors will be individually activated to allow adjustment between fully open and closed positions depending on wind direction relative to the opening of the observing slit doors, wind speed, and the exterior and interior temperatures.

The ventilation doors will be insulated coiling roll-up steel doors. These ventilation doors are available "off-the shelf" and have a proven track record in observatory design. All ventilation doors will be a common size, 3.0m x 3.0m, and will be installed on both the fixed and rotating enclosure walls that share in the common Enclosure volume. The current design incorporates 22 ventilation doors, for a total open area of 207m<sup>2</sup>. The number of doors can be increased or decreased based upon a further review of the Enclosure ventilation requirements.

The ventilation doors will be designed to withstand survival wind pressures and survival seismic requirements. The doors slats will be filled with expanded polystyrene foam to reduce heat buildup within the Enclosure. Weather stripping will be provided around all perimeters to reduce air and dust infiltration. All doors will be motor operated and designed to meet maximum open and close times as defined by the project requirements.

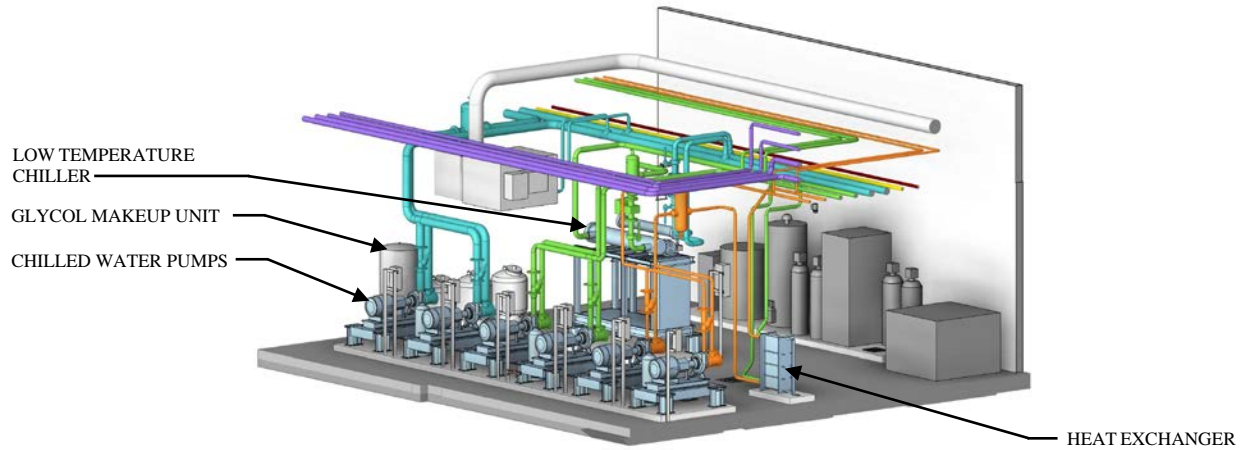

Figure 10.7.1 Support Building Mechanical Room

## 10.8 Support Building

The support building Mechanical room, see figure 9.9.2, will contain all hydronic equipment required to support the building HVAC and Enclosure cooling systems except for the air cooled chiller. Some of the equipment that will be located in the Mechanical room will be a water cooled low temperature chiller, chilled water pumps, heat exchangers, glycol makeup unit, chemical pot feeders, and expansion tanks. The layout will provide maintenance access to all equipment. All chilled water systems will have a primary and backup pump. All vibrating equipment will be located on spring isolators to prevent any vibration from affecting the telescope. Chemical pot feeders and glycol makeup unit will be used to maintain the chilled water system.

## ACKNOWLEDGMENTS

The funding for this planning phase of the TSPM project has been supported in Mexico by the IA-UNAM, the INAOE, and especially the Consejo Nacional de Ciencia y Tecnología through grants LN127736, LN232649, LN 260369, LN 271117, 224003, 264173, and the Agencia Espacial Mexicana who contributed to grant 248500. We gratefully acknowledge the Giant Magellan Telescope for permitting the TSPM project to adopt its control system as our model. We thank personnel at the MMT and Magellan telescopes for making information available.

## REFERENCES

- [1] Personal communication from multiple telescope programs
- [2] Teran, J. et al: M3 Engineering and Technology, Tucson, AZ “San Pedro Mártir Telescope Preliminary Design Report” Revision P1 May 2016
- [3] Richer, M. G., Lee, W. H. et al, “The Telescopio San Pedro Mártir Project,” *Proc. of SPIE* **9906** (2016)